

# HYDRAULIC EXCAVATOR PC81

# KOMATSU®

# PC81



## STANDARD EQUIPMENT

- ▶ 55 A alternator
- ▶ Air cleaner, dry type with dust indicator
- ▶ Autodecel Function
- ▶ Automatic deaeration system for fuel line
- ▶ All-weather steel cab (with tinted safety glass windows, pull-up type front window with lock device, removable lower windshield, lockable door, floor mat, adjustable seat)
- ▶ Blade (2.26 m wide)
- ▶ Cooling fan
- ▶ Counterweight 680 kg (1500 lb)
- ▶ Control levers (wrist control, adjustable)
- ▶ Drive system: hydrostatic, high-low travel system
- ▶ Electric horn
- ▶ Front light (1)
- ▶ Fuel control lever
- ▶ Heavy duty 95 Ah Battery
- ▶ Rear view mirror (RH)
- ▶ Radiator and oil cooler with dust proof net
- ▶ Revolving frame underguards
- ▶ Seat, adjustable
- ▶ Starting motor, 24-volt direct electric
- ▶ Track frames: 5-track/1-carrier roller (each side), 450 mm 18" triple-grouser shoes and hydraulic track adjusters
- ▶ Track roller guard
- ▶ Tool kit
- ▶ Vandalism protection locks
- ▶ Wiper Motor



## OPTIONAL

- ▶ Air Prefilter
- ▶ Bucket Options:
  - Trenching Bucket 0.09 m<sup>3</sup>
  - ME Bucket 0.35 m<sup>3</sup>
  - GP & HD Bucket 0.30 m<sup>3</sup>
- ▶ Cold start kit
- ▶ Front Cab Guard
- ▶ Lifting arrangement of machines
- ▶ Rock breaker
- ▶ Rock breaker Adaptation kit
- ▶ Tunnelling configuration

PC81

PC81



## EQUIP-CARE

Customer Care Number

**1800 833 9990**

[www.Komatsu.com](http://www.Komatsu.com)

# KOMATSU®



Marketed & Serviced by:

## L&T Construction Equipment

**Larsen & Toubro Limited**

1<sup>st</sup> Floor Lakshminarayan Complex, 10/1 Palace Road, Bengaluru- 560 052  
Tel: (080) 40401700

Visit: [www.Lntcmb.com](http://www.Lntcmb.com)



L&T Construction & Mining Machinery



[Larsentoubro.cmb](https://www.instagram.com/larsentoubro.cmb)

### Zonal Offices:

Delhi (011) 40819500

Kolkata (033) 44002433/22831442

Pune (020) 48544259

Jaipur (0141) 4385900

Nagpur (0712) 6606441/2260025

Hyderabad (040) 47575064

Chennai (044) 40706864

CIN: L99999MH1946PLC004768

Contact : 9300723311

Materials and specifications are subject to change without notice.

**KOMATSU** is a trademark of Komatsu Ltd. Japan.

## HYDRAULIC EXCAVATOR

**Built TOUGH**



**Fuel Efficient**



**FLYWHEEL HORSEPOWER**

44.1 kW 60 HP / 1900 rpm

**OPERATING WEIGHT**

7500 kg

**BUCKET CAPACITY**

350L ME

Contact : 9300723311



**HydraMind hydraulic System**

HydraMind is an advanced hydraulic control system that provides the operator with unbeatable feel and precision control. By automatically providing just the right combination of speed and power, even the most complex operations can be tackled with maximum speed and efficiency. This makes the excavator work better at any job site.

**KOMTRAX**

**Information and Communication Technology**

KOMTRAX™ website to optimise your maintenance planning and fleet management



**10% Lower Fuel Consumption**

**Improved Filtration System**

Rotary air pre-cleaner incorporated to deliver clean air to the engine even in dusty situations, extending filter life.

New hybrid hydraulic filter for improved filtration and hydraulic oil life

**Reinforced Structures**

Stronger & Sturdier Boom and Arm with cast ends for high durability.

Reinforced HD arm with bottom safety plate for tough applications .

Rockbreaker adaptation kit clamps provided for ready retrofitment on the machine

**Comfortable cabin and Operating Environment**

Spacious and ergonomic cabin with good visibility and ease of access to controls

Additional lamps for improved night visibility

Cabin Mesh guard for additional Operator safety

**High Productivity 0.35 cu.m ME Bucket**

- Low resistant excavation with the well-engineered bucket to improve fuel efficiency.
- High productivity even in the toughest application with the 'More Efficient' bucket

**Ecology & Economy Features**

- Low fuel consumption
- Auto decelerator to minimize fuel consumption
- Closed-centre load sensing system (CLSS)

HORSEPOWER :	44.1 kW 60 HP @ 1900 rpm
OPERATING WEIGHT :	7500 kg
BUCKET CAPACITY :	0.09 - 0.35 m <sup>3</sup>

**Heavy duty Undercarriage**

Reinforced Idler Guard for better Undercarriage life  
Powerful Dozer Blade with high drawbar pull

**Heavy Duty Dozer Blade**

Powerful dozer blade with high drawbar pull

# ADVANCED HYDRAULIC SYSTEM

The PC81 is equipped with HydraMind, Komatsu's unique hydraulic system

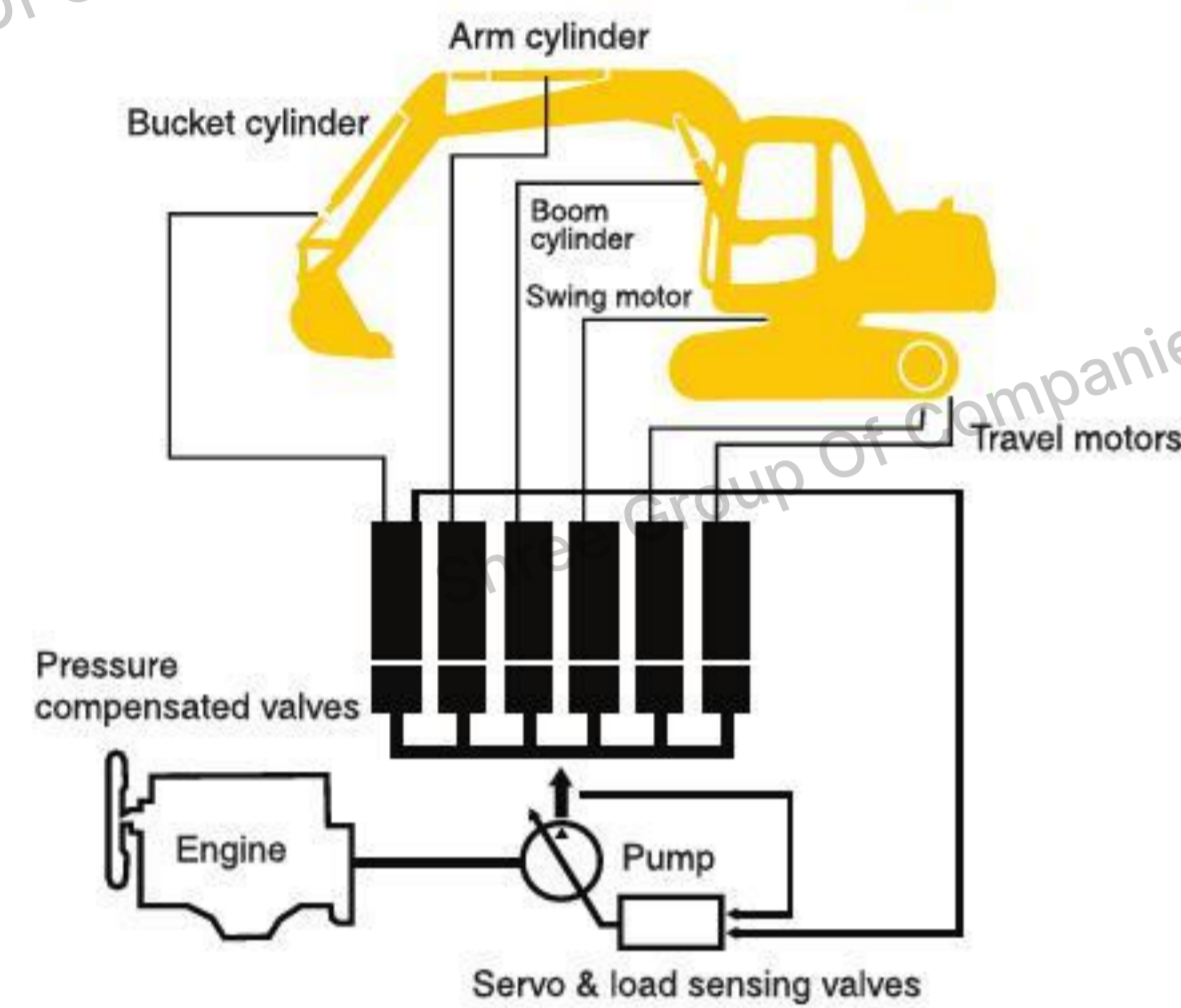

## Benefits of HydraMind

In the HydraMind system, the load-sensing valves and pressure-compensated valves automatically handle all adjustments for individual jobs based on the pressure and the lever stroke detected.

When you move the boom, arm and bucket at the same time, all the equipment works together with the optimum combination of speed and power - as if it were a human hand.

Power, versatility, maneuverability, controllability - you name it. Never has an excavator been so easy to operate, so natural, so intuitive. In a sense, you don't really operate it at all, you wear it.

For example, when the ground condition changes in digging, you don't have to think about changing your lever strokes because the HydraMind instantly, silently, automatically sends just the right amount of oil to the actuators at just the right pressure to accommodate the change.

HydraMind system is one of the most sophisticated yet mechanically convenient hydraulic systems currently available.

The system incorporates many major breakthroughs and has earned Komatsu almost 200 patents.

## ME BUCKET

High Productivity with the latest Low-resistant Excavation technique

The new Ideal bucket profile produces lower resistance inside & outside bucket. This design not only increases production but also reduces fuel consumption

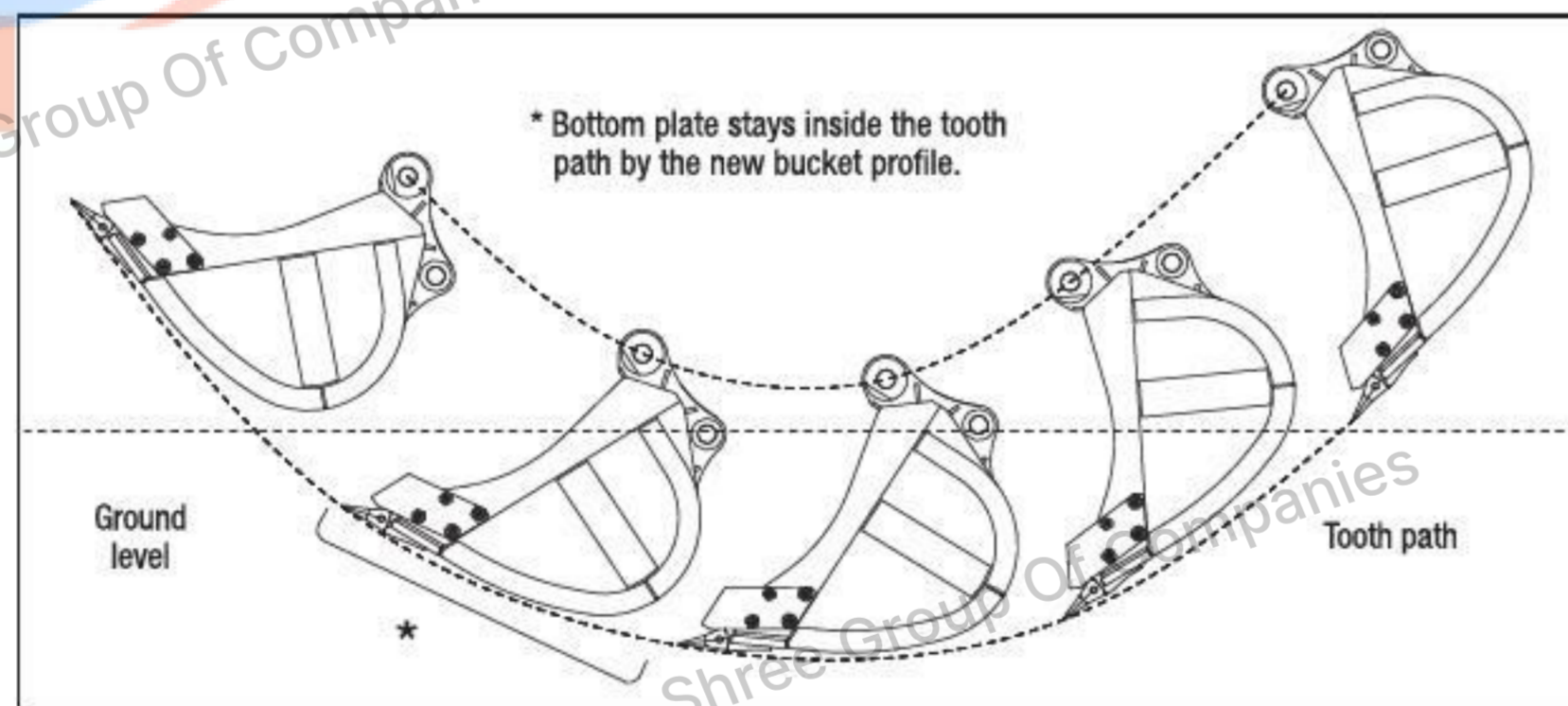

# STRONG FEATURES

## REINFORCEMENT HD ARM



## IDLER GUIDE REINFORCEMENT



## THICKER TRACK SHOE



## ADDITIONAL LAMPS



## TURBO PRE-CLEANER



## RB KIT CLAMP



## CABIN MESH GUARD



## SPACIOUS CABIN



# KOMTRAX

## KOMTRAX™ assists you with:

- **Full machine monitoring**  
Get detailed operation data to know when your machines are used
- **Total fleet management**  
Keep track of the location of your machines at all times and discourage unauthorized usage
- **Easy access to machine information**  
Machine working details can be easily obtained from anywhere using internet facility

**Monitor your machine from anywhere, anytime for complete peace of mind!**



M E M O

# SPECIFICATIONS



## ENGINE

Model.....KOEL 4R-1040  
 Type .....4-cycle, water-cooled, direct-injection  
 Aspiration .....Naturally aspirated  
 No. of cylinders .....4  
 Bore..... **105mm 4.13"**  
 Stroke..... **120mm 4.72"**  
 Piston displacement ..... **4.16ltr 253.63 cu in**  
 Gross Power  
 (SAE J1995) ..... **60 HP 44.1 kW @ 1900 RPM**  
 Net Power  
 (SAE J1349)..... **54 HP 40.3 kW @ 1900 RPM**  
 Governor.....All-speed, mechanical



## HYDRAULIC SYSTEM

Type.....**HydraMind (Hydraulic-Mechanical Intelligence New Design) system**  
 Closed-centre system with load sensing valves and pressure compensated valves

Main pump:  
 Type.....Variable-displacement piston pump  
 Maximum flow.....1 x 155 ltr / min 41.0 U.S. gal/min

Hydraulic motors:  
 Travel .....2 x Axial piston motor with parking brake  
 Swing....1 x Axial piston motor with Swing holding brake

### Relief valve settings:

Implement circuits **250 kg/cm<sup>2</sup> 3,560PSI/ 4.5 MPa**  
 Travel circuits **250 kg/cm<sup>2</sup> 3,560PSI/ 24.5 MPa**  
 Swing circuits **195 kg/cm<sup>2</sup> 2,770PSI/ 19.1 MPa**  
 Pilot circuits **30 kg/cm<sup>2</sup> 430PSI/ 2.9 MPa**  
 Service valve .....**Add-on type (optional)**

### Hydraulic cylinders:

	number of cylinders	bore x stroke
Boom	1	<b>115 mm x 840 mm 4.5" x 33.1"</b>
Arm	1	<b>100 mm x 865 mm 3.9" x 34.1"</b>
Bucket	1	<b>90 mm x 710 mm 3.5" x 28.0"</b>

All hydraulic joints are with O-Ring face seal type (ORFS)



## SWING SYSTEM

Driven by.....Hydrostatic motor  
 Swing reduction .....Planetary gear reduction  
 Swing circle lubrication .....Grease-bathed  
 Swing lock .....Oil disc brake  
 Swing speed.....12.0 RPM



## DRIVES & BRAKES

Steering control.....Two levers  
 Drive method.....Fully hydrostatic type  
 Drive motor .....Axial piston motor, in-shoe design  
 Reduction system .....Eccentric differential planetary gear reduction  
 Max. drawbar pull ..... 5500 kg 12,125 lb/53.9 kN  
 Max. travel speed (High)..... **3.5 km/h 2.2 MPH**  
 Max. travel speed (Low)..... **2.3 km/h 1.4 MPH**  
 Service brake.....Hydraulic lock type  
 Parking brake .....Oil disc brake



## UNDERCARRIAGE

Track frame .....Box section type  
 Seal of track.....Sealed track  
 Track adjuster .....Hydraulic type  
 No. of shoes .....38 each side  
 No. of carrier rollers.....1 each side  
 No. of track rollers .....5 each side

## GROUP

## COOLANT & LUBRICANT CAPACITY (Refill)

Fuel tank ..... **130.0 ltr 34.3 U.S. gal**  
 Radiator..... **17.5ltrs 4.62 U.S. gal**  
 Engine..... **9.6 ltr 2.5 U.S.gal**  
 Final drive, each side ..... **1.7 ltr 0.4 U.S. gal**  
 Swing drive..... **1.5 ltr 0.4 U.S. gal**  
 Hydraulic tank ..... **57.0 ltr 15.1 U.S.gal**



## OPERATING WEIGHT (approximate)

Operating weight, including 3710 mm 12'2" one-piece boom, 1650 mm 5'5" arm, SAE heaped 0.35 m<sup>3</sup> 0.47 cu.yd backhoe HD bucket, operator, lubricant and full fuel tank and the standard equipment.

Triple-Grouser Shoes	Operating Weight	Ground Pressure
450 mm	7500 kg	0.36 kg/cm <sup>2</sup>
18"	(16,535 lb)	5.12 PSI/35.3 kPa

# SPECIFICATIONS

## DIMENSIONS

	Komatsu PC81		
	1.65 m	5'5" arm	2.25 m 7'5" arm
<b>A Overall length</b>	6080 mm	19'11"	6105 mm 20'
<b>B Length on ground (transport)</b>	3645 mm	12'	3515 mm 11'6"
<b>C Overall Height (to top of boom)</b>	2500 mm	8'2"	2830 mm 9'3"
<b>D Overall width</b>	2225 mm 7'4"		
<b>E Overall height (to top of cab)</b>	2590 mm 8'6"		
<b>F Ground clearance, counterweight</b>	750 mm 2'6"		
<b>G Min. ground clearance</b>	350 mm 1'2"		
<b>H Tail swing radius</b>	1750 mm 5'9"		
<b>I Length of track on ground</b>	2130 mm 7'		
<b>J Track length</b>	2765 mm 9'1"		
<b>K Track gauge</b>	1700 mm 5'7"		
<b>L Width of crawler</b>	2150 mm 7'1"		
<b>M Shoe width</b>	450 mm 1'6"		
<b>N Grouser height</b>	20 mm 0.79"		
<b>O Machine cab height</b>	1810 mm 5'11"		
<b>P Machine cab width</b>	2180 mm 7'2"		
<b>Q Distance, swing center to rear end</b>	1750 mm 5'9"		

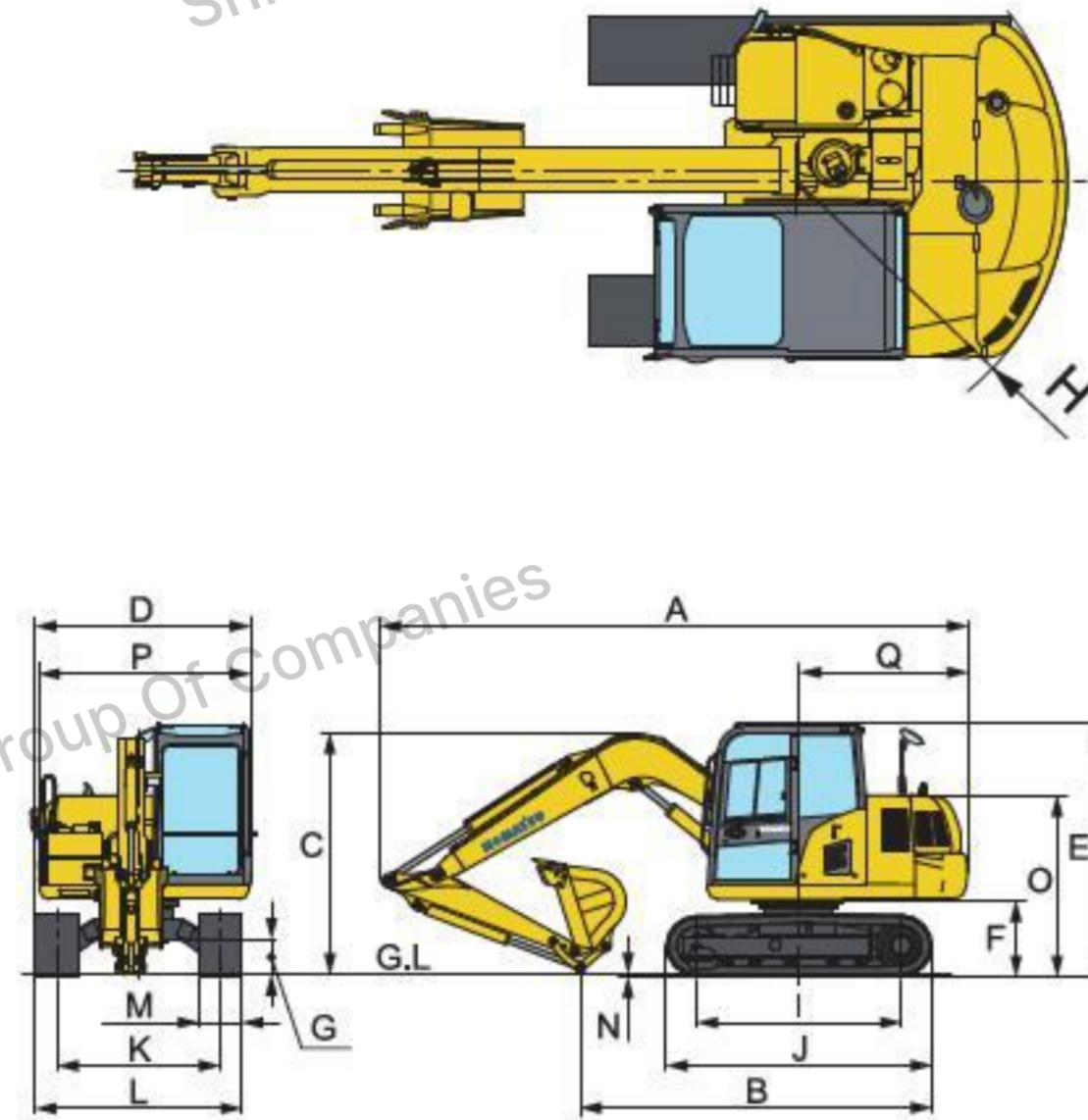

## WORKING RANGE

Komatsu PC81	WITH 3.71 m BOOM	WITH 2.62 m TUNNEL BOOM	
<b>Arm</b>	1.65 m 5'5" arm	2.25 m 7'5" arm	1.65 m 5'5" arm
<b>A Max. digging height</b>	7150 mm 23'6"	7515 mm 25'	5575 mm 18'4"
<b>B Max. dumping height</b>	5015 mm 16'5"	5420 mm 18'	3670 mm 12'1"
<b>C Max. digging depth</b>	4100 mm 13'5"	4690 mm 15'5"	3235 mm 10'7"
<b>D Max. vertical wall digging depth</b>	3135 mm 10'3"	3610 mm 11' 10"	1765 mm 5'0"
<b>E Max. digging reach</b>	6360 mm 20'10"	6900 mm 23'	5040 mm 16'6"
<b>F Max. digging reach at ground level</b>	6220 mm 20'5"	6770 mm 22'4"	4860 mm 15'4"
<b>G Min. swing radius</b>	1750 mm 5'9"	2075 mm 6'8"	1975 mm 6'6"
<b>Bucket digging force</b>	4800 kg 10,580 lb/47.1 kN	4800 kg 10,580 lb/47.1 kN	4800 kg 10,580 lb/47.1 kN
<b>Arm crowd force</b>	3600 kg 7,940 lb/35.3 kN	3050 kg 6,720 lb/29.9 kN	3600 kg 6,940 lb/35.3 kN

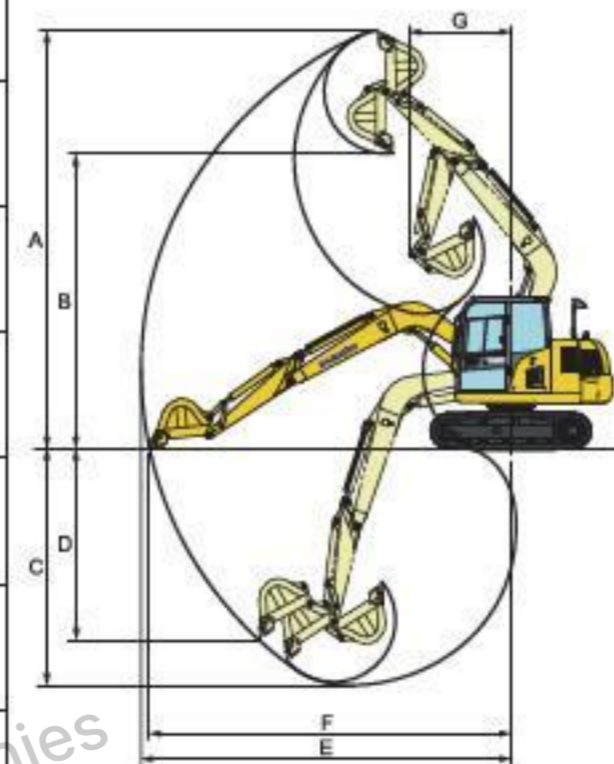

## BUCKET OPTIONS

Bucket capacity (heaped)		Width		Weight (with side cutter)	No. of teeth	Arm	
SAE PCSA	CECE	Without side cutters	With side cutters			1.65m 5'5"	2.25m 7'5"
0.09 m <sup>3</sup> 0.12 cu. yd	0.08 m <sup>3</sup> 0.10 cu. yd	350 mm 13.8"	450 mm 17.7"	145 kg 320 lb	3	○	○
0.30 m <sup>3</sup> (GP) 0.40 cu. yd	0.27 m <sup>3</sup> 0.36 cu. yd	790 mm 31.1"	890 mm 35.0"	236 kg 520 lb	4	○	△
0.30 m <sup>3</sup> (ROCK) 0.40 cu. yd	0.27 m <sup>3</sup> 0.36 cu. yd	—	785 mm 30.9"	267 kg 588 lb	4	○	△
0.35 m <sup>3</sup> (ME) 0.47 cu. yd	0.32 m <sup>3</sup> 0.43 cu. yd	760 mm 29.9"	800 mm 31.50"	265 kg 584 lb	4	○	△

These charts are based on over-side stability with fully loaded bucket at maximum reach. ○ General purpose use, weight up to 1.8 t/m<sup>3</sup> 1.52 U.S. ton/cu yd  
△ Material weight up to 1.2 t/m<sup>3</sup> 1.01 U.S. ton/cu yd

## LIFTING CAPACITY

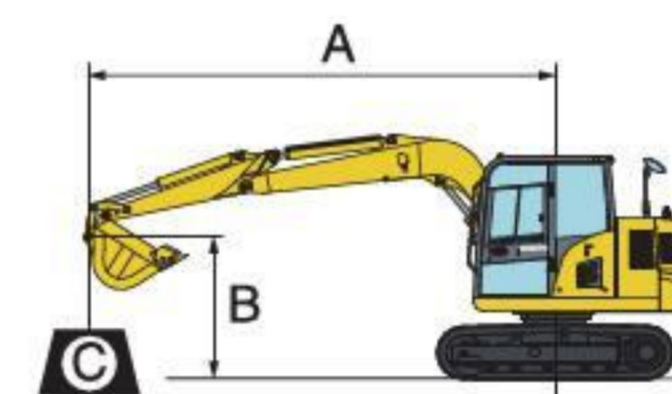

- A :** Reach from swing center  
**B :** Bucket hook height  
**C :** lifting capacity  
**Cf :** Rating over front  
**Cs :** Rating over side  
**⊖ :** Rating at maximum reach
- Conditions:**  
 • 3710 mm 12' 2" one-piece boom  
 • 1650 mm 5' 5" arm  
 • 0.35 m<sup>3</sup> 0.47 cu. yd SAE heaped HD bucket  
 • 450 mm 18" triple-grouser shoes

A \ B	⊖ Max	5.5m (18')		4.5m (15')		3m (10')		1.5m (5')	
		Cf	Cs	Cf	Cs	Cf	Cs	Cf	Cs
6m (20')	*1550 3400	*1550 3400							
4.5m (15')	*1350 3000	1300 2900				*1300 2850	*1300 2850		
3m (10')	1050 2300	900 2000		1400 3100	1200 2650	*1800 3950	*1800 3950	*3150 6950	*3150 6950
1.5m (5')	950 2100	800 1750	900 2000	800 1750	1350 3000	1150 2550	*2500 5500	2200 4850	
0 (0)	950 2100	800 1750			1250 2750	1050 2300	2400 5300	2000 4400	
-1.5m (-5')	1200 2650	1000 2200			1250 2750	1050 2300	2400 5300	1950 4300	*4500 9900
-3m (-10')	*1400 3100	*1400 3100					*1600 3550	*1600 3550	

\* Load is limited by hydraulic capacity rather than tipping. Ratings are based on SAE Standard No. J 1097. Rated loads do not exceed 87% of hydraulic lift capacity or 75% of tipping load.