



L&T Construction & Mining Machinery

L&T 990HF *i* TANDEM COMPACTOR

Contact: 9300723311

Operating Weight: **9,200 kg**
Frequency: **60/42Hz**
Gross Power: **74.8 hp @ 2200 rpm**
Engine: **Mahindra & Mahindra VNEF74**

Improved



Manufactured by

L&T Construction Equipment Limited



Wide drum for better productivity

Higher frequency for best-in-class road surface finish

Rotating operators station improves edge visibility

Suspended frame for better kerb clearance

Fuel efficient M&M VNEF74 Engine

High drum shell thickness for superior life

Auto vibration cut-off when machine is stationary to avoid scuffing

**Optimal
operating weight delivers
better compaction in
lesser number of passes**

**Isolated operator
platform for better
operator comfort**

**Foldable canopy for
ease of transportation**

**Better illumination for
working during nights**

**Open-to-Sky drum
for better drum
visibility**

**Wide angle
water spray
nozzle with
flow controller**

**Fully openable hood
for enhanced serviceability**

**Efficient
filtration system
for better component life**



OPERATOR CABIN

- ▶ Revolving operator station with 5-position lock
- ▶ Separate isolation for front console & steering wheel improves operator comfort
- ▶ Ergonomically designed switches
- ▶ Glove box, mobile recharge point
- ▶ All switches are easily accessible, emergency stop button is provided
- ▶ Wide rear view mirror for better visibility



Better all round operator visibility



Clear drum edge visibility



Vandal Protection



PRODUCTIVITY

Soil Compaction	Sand & Gravel	Mixed Soil	
Compacted Lift thickness (in mm)	500	400	
Productivity (in CuM/hour)	250-500	200-400	
Bitumen	Wear Course	Binder Course	Base Course
Layer thickness (in mm)	20-40mm	60-80mm	100-140mm
Area output (m ² /hour)	1200-2100	700-1150	600-950
Productivity (in Tonnes/hour)	75-150	120-240	160-280

ENGINE

- ▶ Mahindra & Mahindra VNEF74, water cooled, 4-cylinder, 4-stroke Inline turbocharged intercooled engine-CEV-IV compliant
- ▶ Pre filter, Fuel filter cum Water separator for better filtration



SUPERIOR SUSPENDED FRAME DESIGN

- ▶ Better kerb clearance for working near road medians
- ▶ Better visibility of the drum edge and sprinkler nozzles
- ▶ Open-to-Sky drum for better drum visibility
- ▶ Easy access to water sprinkling nozzles



HIGH GRADEABILITY

- ▶ Capable of climbing 40% gradient
- ▶ High ground clearance
- ▶ Machine can work in hilly terrains and steep slopes



WORLD CLASS HYDRAULIC COMPONENTS

- ▶ "Closed circuit" hydraulic system with best-in-class hydraulic components
- ▶ Hydraulic System designed for optimising productivity



SERVICEABILITY

- ▶ Excellent air flow for better engine and hydraulic system cooling
- ▶ Fully openable hood
- ▶ Easy access for machine maintenance
- ▶ Refill points accessible from ground level



Foldable canopy for ease of transportation



MACHINE DIMENSION

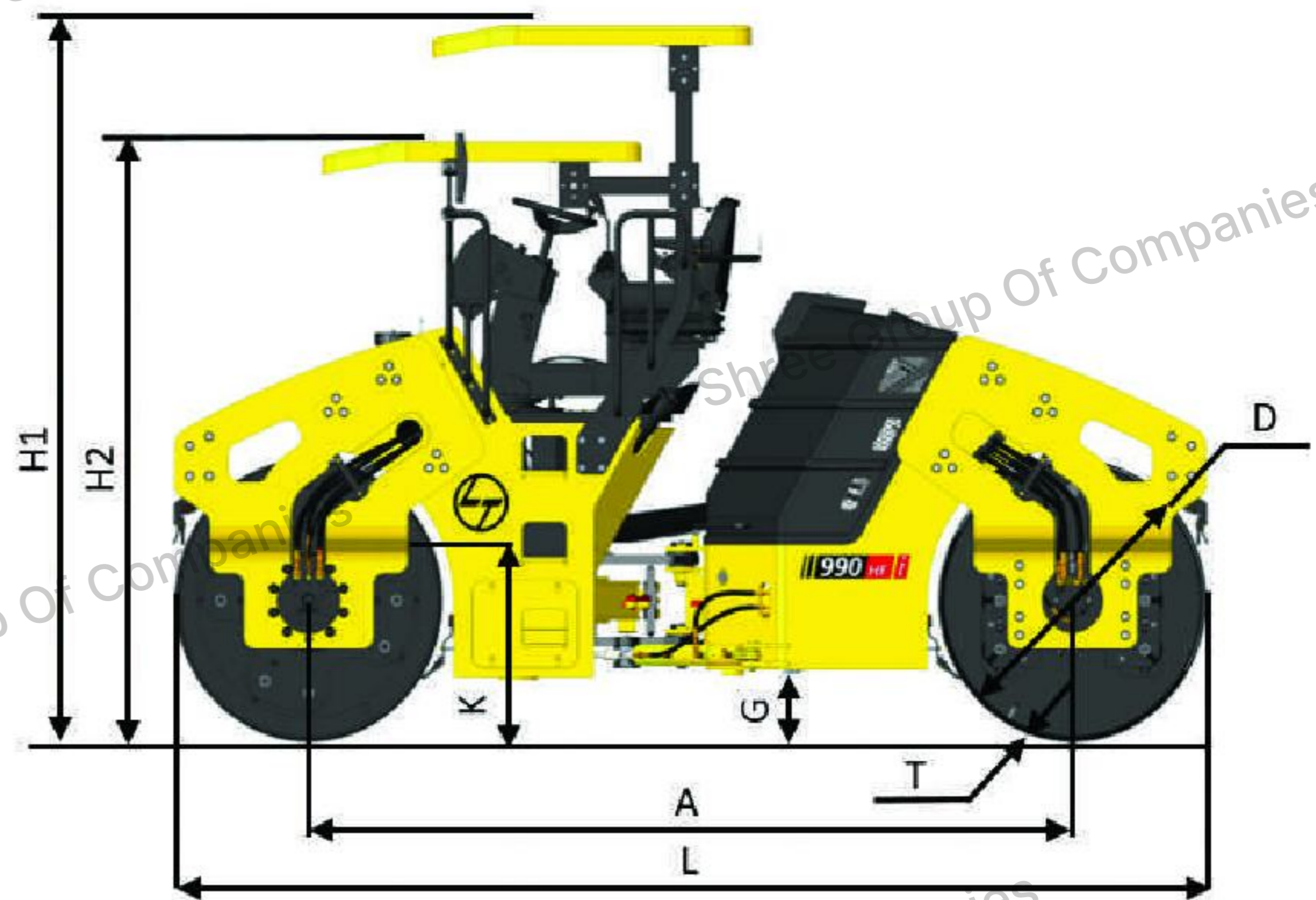

A	B	D	G	H1	H2	K	L	O	T	W
3480	1834	1220	300	3025	2575	800	4700	80	19	1680

All Dimensional Parameters are within $\pm 2.5\%$ of the Specified values

H2-Transport Height

SPECIFICATIONS**MACHINE WEIGHT**

Operating weight (kgs)	9200
Working weight (kgs)	9575
Static weight @ front/Rear drum (kgs)	4600 / 4600
Static Linear load Front/Rear (Kg/cm)	27.4 / 27.4

VIBRATION SYSTEM

Vibration Stage	2
Frequency (Hz)	42/60
Amplitude (mm)	0.9 / 0.36
Centrifugal Force (Kgf)	7515 / 5402

DRUMS

Width (mm)	1680
Diameter (mm)	1220
Shell thickness (mm)	19
Finish	Machined Drum with chamfered edges

TRAVEL

Type	Hydrostatic drive with Infinitely variable displacement axial piston pump
Drum Drive motors	Heavy-Duty Radial Piston Motors

MACHINE SPEED

Maximum Working speed	6 KMPH
Maximum Travel speed	12 KMPH

GRADEABILITY (Theoretical)

Working Gradient	36%
Travel Gradient	40%

ENGINE

Make	Mahindra & Mahindra
Model	VNEF74
Type	4 Stroke Inline Turbocharged Intercooled CEV-IV
Cylinder (nos)	4
Bore/Stroke	96mm x122mm
Displacement	3532 cc
Fuel Injection	Common Rail Direct injection
Fuel	BS VI diesel
Fuel filter Cum Water separator	Spin-on type
Air Filter	Dry Type with Dual Element
Engine oil filter	Spin-on type
Cooling	Liquid
Horse power (Gross)	74.8 HP @ 2200 rpm as per ISO 1585
Torque (Max)	306 Nm @ 1200-1500 rpm

SAFETY

- All-weather canopy
- 2 point seatbelt
- CMVR compliant handrails & steps
- Automatically applied parking brake in case of engine shutdown

WATER SYSTEM

Type	Pressure spray sprinkling system
Pumps	2 nos. of Diaphragm water pumps
Spray Bars	1 bar on each drum (6 nozzels per bar)
Filtration	Triple filtration
Drum Scraper (per drum)	2
Water Tank Capacity	750 L

MISCELLANEOUS

Steering Angle	±33°
Turning Radius (inner)	5 m
Drum Oscillation Angle	±10°

ELECTRICAL

Alternator	90 Amps
Battery (V / Ah)	12V / 150 Ah

SERVICE CAPACITIES

Fuel Tank Diesel	140 L
Hydraulic Oil	65 L
Engine Oil	14 L
Engine Coolant	14 L

BRAKES

Service Brake	Hydrostatic Brake
Parking Brake	Spring Applied Hydraulically Released (SAHR)

STANDARD EQUIPMENT

- Higher Drum Shell Thickness
- Single hood for engine compartment
- Rear work lamps
- Foldable Canopy
- Rotating operator station
- Front & Rear Handrails
- Mobile charging Point, Water bottle holder, Utility/Tool box
- Weather proof rocker switches
- Instrument cluster
- Rust proof LLDPE water tank

OPTIONAL EQUIPMENT

- Intelligent compaction system (ICS)
- Beacon Lamp

WARNING ALARMS

- Coolant overheat
- Low lube oil pressure
- Hydraulic oil filter clog
- Parking brake
- Battery Changing
- Engine Check
- Engine Stop
- Water in Fuel

INDICATORS

- Travel mode
- Engine coolant temperature
- Battery charging
- Lube oil pressure
- Parking brake
- Engine Check
- Engine Stop
- Air filter clog

GAUGES

- Lube Oil Pressure
- LCD hour Meter
- Engine Water Temp
- Fuel Level
- Water Level
- Engine RPM
- Error code
- Battery Voltage

32, Shivaji Marg, P.O. Box 6223
New Delhi 110 015
Tel : (011) 40819500

Aspire Towers
Plot No: 55, 4th Floor
Industrial Area Phase - 1
Chandigarh 160 002
Tel : (0172) 4646846

A-28 Indiranagar
Faizabad Road, First Floor
Lucknow 226 016
Tel : 0522- 4929920

Monarch Building
D-236 & 237, Amrapali Marg
Vaishali Nagar, **Jaipur** 302021
Tel : (0141) 4385900

Shree Ram Plaza, 2,3 & 4
1st Floor, Siphon Chauraha
Bedla Road-**Udaipur** 313 001
Tel : (0294) 2451 337, 2451 305

3-B, Shakespeare Sarani,
P.O.Box 619, **Kolkata** 700 071
Tel : (033) 4400 2433/22831442

Annapoorna Complex
Plot No. 559, Lewis Road
Bhubaneswar 751 014, **Odisha**
Tel : 9777049626

A1/11, Degaul Avenue
Khoirasol, **Durgapur** 713 212
Tel : 9830057293

Milanpur Road, Bamuni Maidan
Guwahati 781 021
Tel : (0361) 4415/4412
8876554415

101/A, Dumardaga
PO Booti
Ranchi 835 217
Jharkhand
Tel: 9771493164

L&T-House, P.O.Box 119
191/1, Dhole Patil Road
Pune 411 001
Tel : (020) 48544259

501, Sakar Complex
Opp. Gandhigram Rly. Stn.
Ahmedabad 380 009
Tel : 7949004005

AMN Tower, MIPD - 5th Floor (Q4)
L&T Campus, Gate No. 3,
Jogeshwari-Vikhroli Link Road,
Powai, **Mumbai** - 400 072
Ph : 022- 68125813/ 5817/5822

Radhadaya Complex
Near Charodar Complex,
Old Padra Road, **Vadodara** 390 015
Tel : (0265) 2334 799

12, Shivaji Marg
North Ambazari Road,
Nagpur 440 010
Tel : (0712) 6606441/2260025

131/1 Zone II
Maharana Pratap Nagar,
Bhopal 462 011
Tel : (0755) 3080522

Crystal Tower, IVth Floor
G. E. Road, Telibandha
Raipur (CG) 492006
Tel: 9752544407

II Floor, Vasantha Chambers
5-10-173 Fateh Maidan Road
Hyderabad 500 004
Tel : (040) 47575064

38, Cubbon Road
Bengaluru 560 001
Tel : (080) 46136139/37

Skybright Building, M.G. Road,
Ravipuram Junction, P.O.Box 1723,
Ernakulam, **Kochi** 682 016
Tel : (0484) 4409401/409

L&T Construction Campus
TC-1 Building, 2nd Floor,
Mount Poonamallee Road,
Manapakkam, **Chennai** 600 089
Tel: (044) 40706864

No. 73, 8th Street,
Karpaga Nagar,
K. Pudur, **Madurai** 625 007.
Tel: 9003944322

Post Bag 7156
67, Appuswamy Road
Coimbatore 641 045
Tel : 9886300106

53-13-2 First Floor, Bank Colony
Srinivasanagar
Vijayawada 520 008
Tel : 9061472255

D No 49-38-14/3/2, 1st Floor,
NGO's Colony, Akkayapalem,
Visakhapatnam - 530 016
Tel: 0891 - 2711121/124



EQUIP-CARE

Customer Care Number
1800 833 9990



Marketed & Serviced by:

L&T Construction Equipment

Larsen & Toubro Limited

1st Floor Lakshminarayan Complex, 10/1 Palace Road, Bengaluru- 560 052
Tel: (080) 22256982/83/84, 40401700

Visit: www.Lntcmb.com



L&T Construction & Mining Machinery



Larsentoubro.cmb

Zonal Offices:

Delhi (011) 40819500

Kolkata (033) 44002433/22831442

Pune (020) 48544259

Jaipur (0141) 4385900

Nagpur (0712) 6606441/2260025

Hyderabad (040) 47575064

Chennai (044) 40706864