

# KOMATSU®

## PC450LC-7

**PC**  
**450**

**FLYWHEEL HORSEPOWER**  
Net: 330 HP 246 kW @ 1850 RPM

**OPERATING WEIGHT**  
45,000 kg 99,210 lb

**BUCKET CAPACITY**  
2.6 – 3.1 m<sup>3</sup> (SAE)  
2.2 m<sup>3</sup> (SAE) - Iron Ore  
1.9 m<sup>3</sup> (SAE) - Granite



Photos may include optional equipment.  
Contact : 9300723311

# WALK-AROUND

## Unmatched Productivity

- Powered by heavy duty Komatsu SAA6D125 diesel engine
- Active mode for fast cycle times & higher production
- Advanced CLSS hydraulics for fine control and quick working speeds
- **Two Boom Setting:** Smooth & Power modes can be toggled to change the operation depending on the application

See page 4.

## Excellent Durability

- High rigidity work equipment with cast end boom top
- Sturdy frame structure
- Reliable Komatsu manufactured major components

See page 7.

## Easy Maintenance

- Long replacement intervals of oils & filters
- Self-Diagnostic Monitor: The advanced Komatsu diagnostic system facilitates easy service by reducing diagnostic time and indicating components due for replacement/ maintenance
- Continuous Machine Monitoring System continuously monitors and checks all working parameters right from the engine ignition. The operator is alerted only in case of abnormalities, so that full concentration is ensured on the job

See page 9.

## Durable Components

- Reliable Komatsu major components
- Heavy duty Boom & Arm

See page 7.

# SPECIFICATIONS



## ENGINE

Model .....Komatsu SAA6D125E-3  
 Type.....Water-cooled, 4 cycle, direct injection  
 Aspiration.....Turbocharged, after-cooled  
 Number of cylinders.....6  
 Bore.....125 mm 4.92"  
 Stroke.....150 mm 5.91"  
 Piston displacement.....11.04 ltr 674 cu.in  
 Flywheel Horse Power:  
 ISO9249/SAE J1349.....Gross **347 HP** 259 kW  
 .....Net **330 HP** 246 kW  
 Reted rpm.....1850 rpm  
 Governor.....All-speed control, electronic  
 Meets 2001 EPA, EU, and Japan Tier-2 emission regulations.



## HYDRAULICS

Type .....**HydrauMind** (Hydraulic Mechanical Intelligence New Design) system, closed-center system with load sensing valves and pressure compensated valves  
 Number of selectable working modes .....3  
 Main Pump:  
 Type .....Variable displacement piston type  
 Pumps for..... Boom, arm, bucket, swing, and travel circuits  
 Maximum flow .....**690 ltr/min** 182 US gal/min  
 Supply for control circuit .....Self-reducing valve  
 Hydraulic motors:  
 Travel .....2 x axial piston motor with parking brake  
 Swing .....1 x axial piston motor with swing holding brake  
 Relief valve setting:  
 Implement circuits .....**37.3 MPa** 380 kgf/cm<sup>2</sup> 5,400 psi  
 Travel circuit .....**37.3 MPa** 380 kgf/cm<sup>2</sup> 5,400 psi  
 Swing circuit .....**27.9 MPa** 285 kgf/cm<sup>2</sup> 4,050 psi  
 Pilot circuit .....**3.2 MPa** 33 kgf/cm<sup>2</sup> 470 psi  
 Hydraulic cylinders:  
 (Number of cylinders – bore x stroke x rod diameter)  
 Boom .....2 – 160 mm x 1570 mm x 110 mm  
 Arm .....1 – 185 mm x 1820 mm x 120 mm  
 Bucket .....1 – 185 mm x 1160 mm x 120 mm  
 1.9 m3 Buck.....1 – 160 mm x 1270 mm x 110 mm



## DRIVES AND BRAKES

Steering control .....Two levers with pedals  
 Drive method .....Hydrostatic  
 Maximum drawbar pull .....**329 kN** 33510 kgf 73,880 lb  
 Gradeability .....70%, 35°  
 Maximum travel speed: High .....**5.5 km/h** 3.4 mph  
 Low.....**3.0 km/h** 1.9 mph  
 Service brake .....Hydraulic lock  
 Parking brake .....Mechanical disc brake

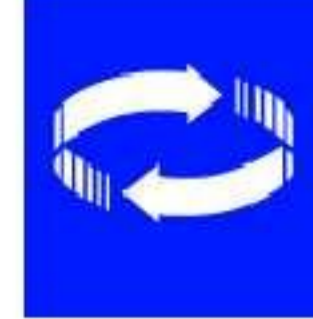

## SWING SYSTEM

Drive method .....Hydrostatic  
 Swing reduction .....Planetary gear  
 Swing circle lubrication .....Grease-bathed  
 Service brake .....Hydraulic lock  
 Holding brake/Swing lock .....Mechanical disc brake  
 Swing speed .....9.0 rpm



## UNDERCARRIAGE

Center frame .....X-frame  
 Track frame .....Box-section  
 Seal of track .....Sealed track  
 Track adjuster .....Hydraulic  
 Number of shoes (each side) .....49  
 Number of carrier rollers .....2 each side  
 Number of track rollers (each side) .....8



## COOLANT AND LUBRICANT

Fuel tank .....**650 ltr** 172 U.S. gal  
 Coolant .....**34.2 ltr** 9.0 U.S. gal  
 Engine .....**38.0 ltr** 10.0 U.S. gal  
 Final drive, each side .....**12.0 ltr** 3.2 U.S. gal  
 Swing drive .....**16.2 ltr** 4.3 U.S. gal  
 Hydraulic tank .....**248 ltr** 65.5 U.S. gal



## OPERATING WEIGHT

Operating weight including 7060 mm 23'2" one-piece boom, 2400 mm 7'10" arm, SAE heaped 2.6 m<sup>3</sup> (3.4 yd<sup>3</sup> bucket) capacity of lubricants, coolant, full fuel tank, operator, and standard equipment.

Komatsu PC450LC-7		
Shoes	Operating Weight	Ground Pressure
600 mm 23.6"	45,000 kg 99,210lb	79.5 kPa 0.81 kgf/cm <sup>2</sup> 11.5 psi



**PC450LC-7 DIMENSIONS**

Contact : 9300723311

	Configuration	7.06 m Boom, 2.4 m Arm		6.67 m Boom, 2.4 m Arm		7.06 m Boom, 2.9 m Arm	
A	Overall Length	11905 mm	39'7"	11520 mm	37'10"	11995 mm	39'4"
B	Length on ground (transport)	8375 mm	27'6"	5920 mm	19'5"	7475 mm	24'6"
C	Overall height (to top of boom)	3850 mm	12'8"	3825 mm	12'7"	3745 mm	12'3"
D	Overall width	3340 mm	11'0"	3340 mm	11'0"	3340 mm	11'0"
E	Overall height (to top cab)	3265 mm	10'9"	3265 mm	10'9"	3265 mm	10'9"
F	Ground Clearance, counter weight	1320 mm	4'4"	1320 mm	4'4"	1320 mm	4'4"
G	Ground Clearance (minimum)	550 mm	1'10"	550 mm	1'10"	550 mm	1'10"
H	Tall swing radius	3645 mm	12'0"	3645 mm	12'0"	3645 mm	12'0"
I	Track length on ground	4350 mm	14'3"	4350 mm	14'3"	4350 mm	14'3"
J	Track length	5355 mm	17'7"	5355 mm	17'7"	5355 mm	17'7"
	Track gauge	2740 mm	9'0"	2740 mm	9'0"	2740 mm	9'0"
L	Width of Crawler	3340 mm	10'11"	3340 mm	10'11"	3340 mm	10'11"
M	Shoe width	600 mm	23.6"	600 mm	23.6"	600 mm	23.6"
N	Grouser height	37 mm	1.5"	37 mm	1.5"	37 mm	1.5"
O	Machine cab height	2715 mm	8'11"	2715 mm	8'11"	2715 mm	8'11"
P	Machine cab width	2995 mm	9'10"	2995 mm	9'10"	2995 mm	9'10"
Q	Distance, swing center to rear end	3605 mm	11'10"	3605 mm	11'10"	3605 mm	11'10"

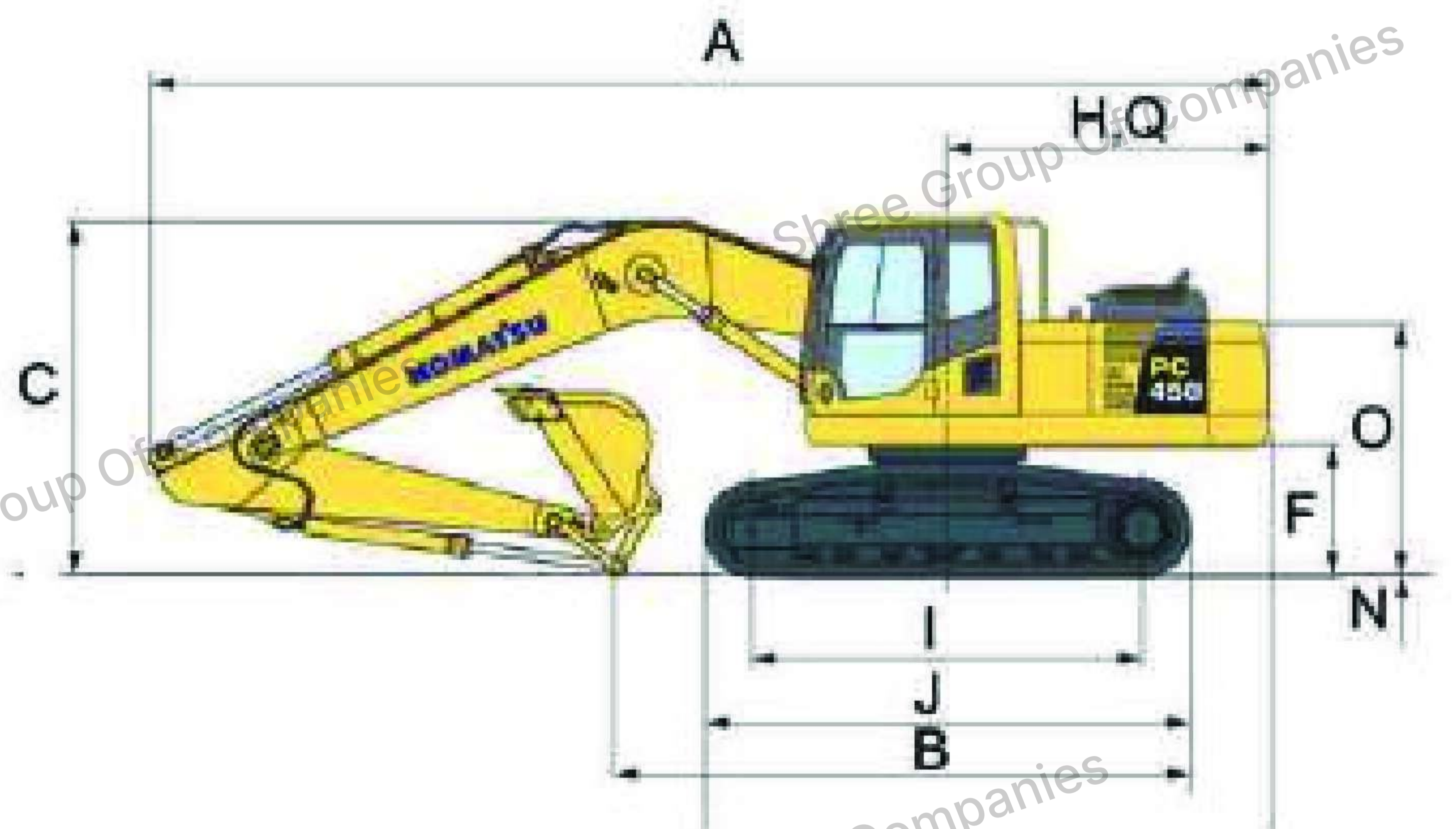
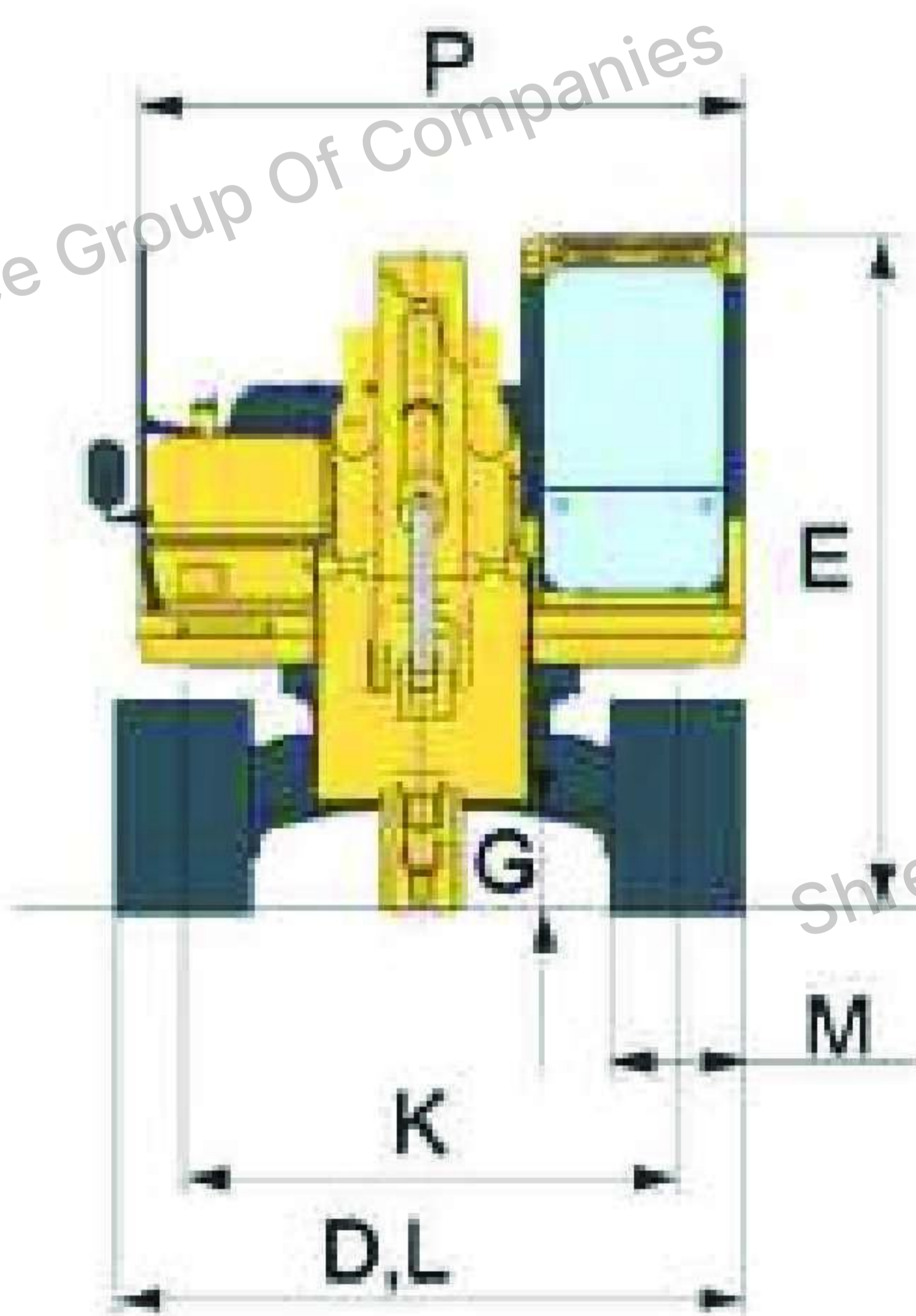



**WORKING RANGE**

CONFIGURATION		7.06 m Boom, 2.4 m Arm		6.67 m Boom, 2.4 m Arm		7.06 m Boom, 2.9 m Arm	
A	Max. digging height	10135 mm	33'3"	10175 mm	33'5"	10315 mm	33'10"
B	Max. dumping height	6845 mm	22'5"	6745 mm	22'2"	7030 mm	23'1"
C	Max. digging depth	7040 mm	23'1"	6700 mm	22'0"	7375 mm	24'2"
D	Max. vertical wall digging depth	3660 mm	12'0"	3090 mm	10'2"	5350 mm	17'7"
E	Max, digging depth of cut for 8'level	6850 mm	22'6"	6530 mm	21'5"	7210 mm	23'8"
F	Max. digging reach	11235 mm	36'10"	11055 mm	36'3"	11500 mm	37'9"
G	Max. digging reach at ground level	11015 mm	36'2"	10825 mm	35'6"	11280 mm	37'0"
H	Min. swing radius	4890 mm	16'1"	4605 mm	15'1"	4810 mm	15'9"
SAE Rating	Bucket digging force at power max	287 kN 29,300 kgf/64,500 lb				240 kN 24,500 kgf/ 54010 lb	
	Arm crowd force at power max	273 kN 27,900 kgf/61,400 lb				245 kN 25,000 kgf/ 55120 lb	
ISO Rating	Bucket digging force at power max	327 kN 33,400 kgf/73,600 lb				276 kN 28,100 kgf/ 61950 lb	
	Arm crowd force at power max	311 kN 31,700 kgf/70,000 lb				257 kN 26,200 kgf/ 57760 lb	

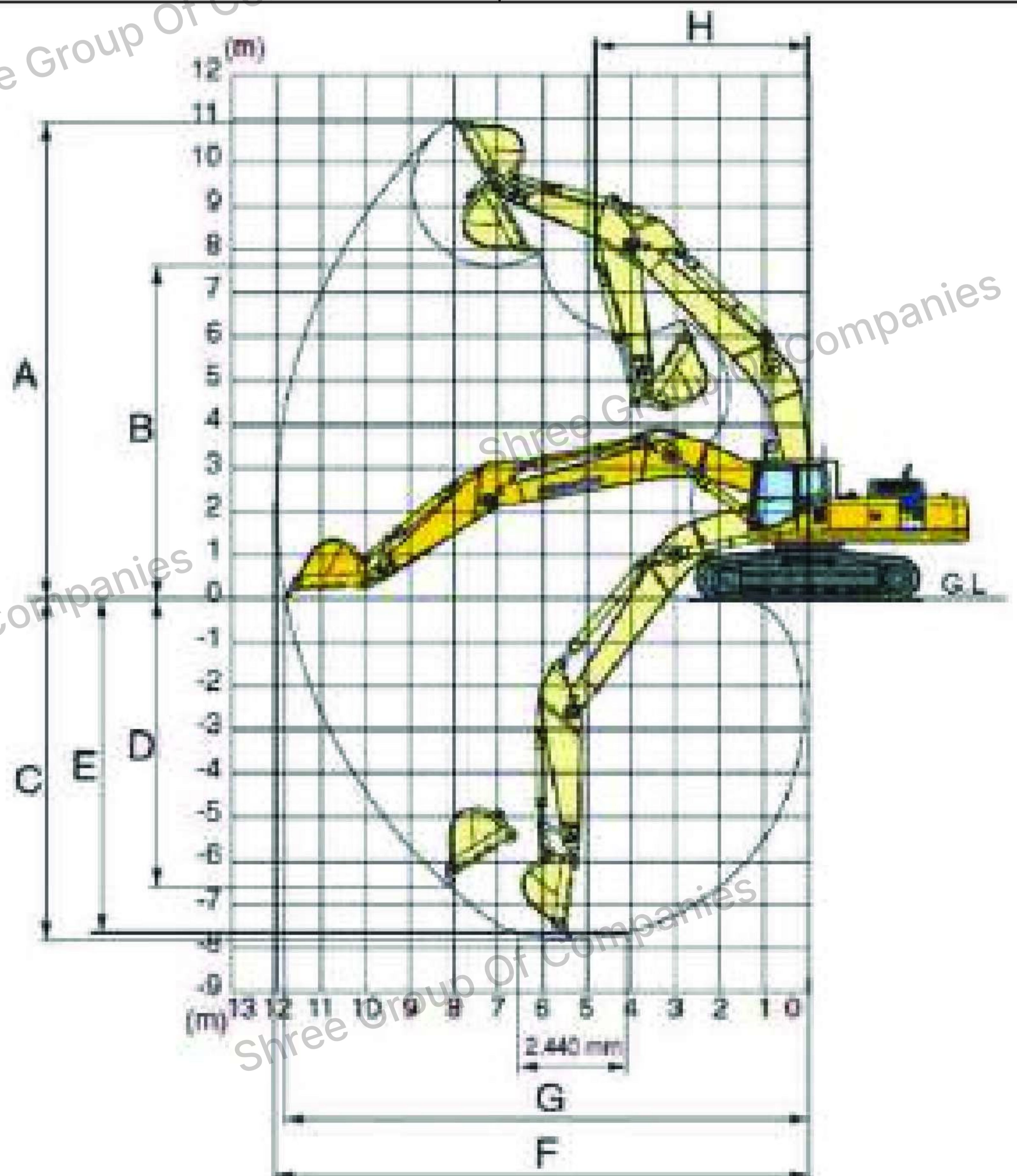



# LIFTING CAPACITY

Contact : 9300723311

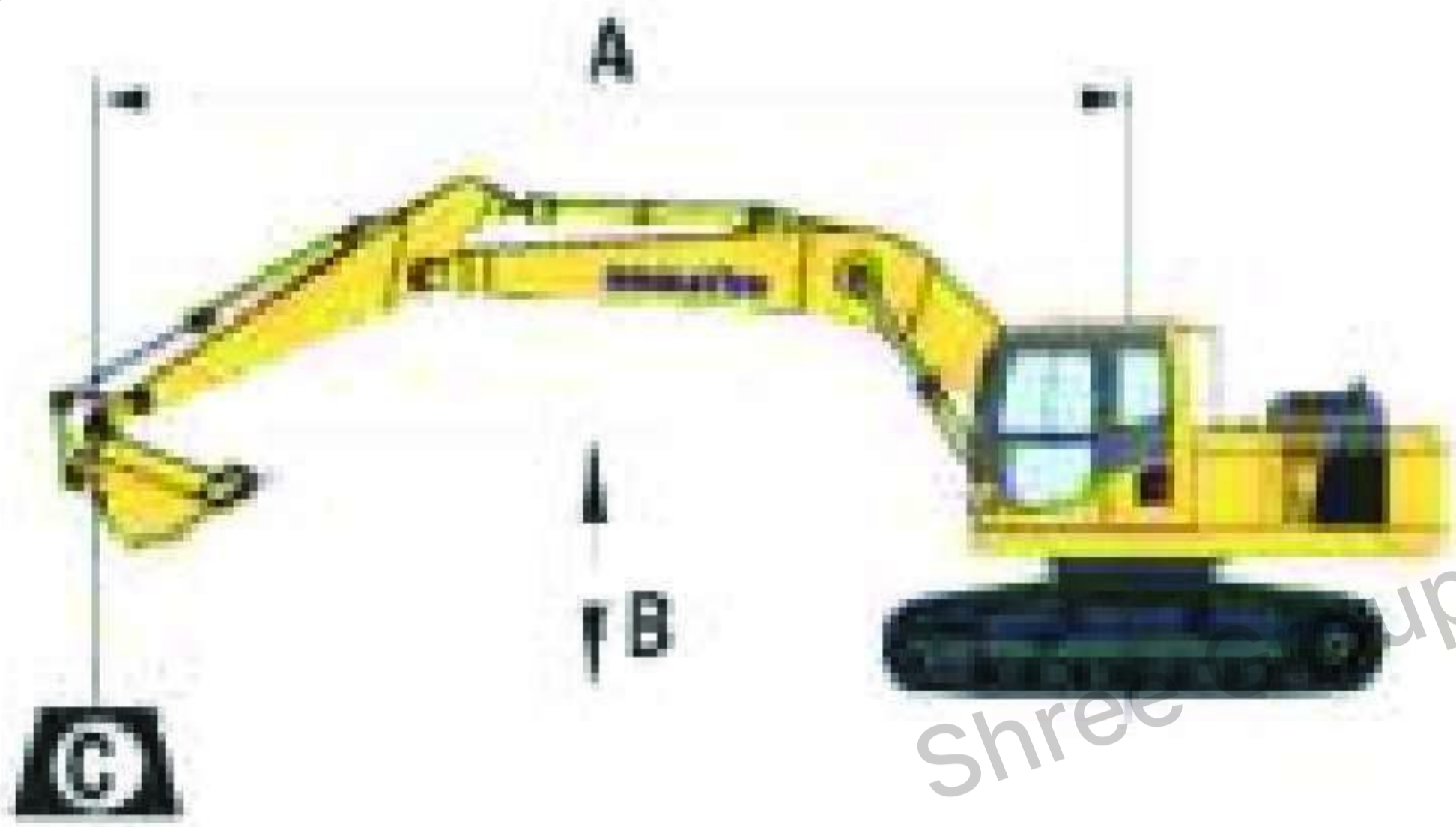

- A : Reach for swing centre
- B : Bucket height
- C : Lifting Capacity
- C<sub>f</sub> : Rating over front
- C<sub>s</sub> : Rating over side
- ⊗ : Rating at maximum reach

## PC450LC-7 – 6.67 m Boom x 2.4 m Arm x 3.1 m<sup>3</sup> Bucket SAE Heaped

A \ B		⊗ Max		7.5 m		6.0 m		4.5 m		3.0 m	
		C <sub>f</sub>	C <sub>s</sub>	C <sub>f</sub>	C <sub>s</sub>	C <sub>f</sub>	C <sub>s</sub>	C <sub>f</sub>	C <sub>s</sub>	C <sub>f</sub>	C <sub>s</sub>
6.0 m	kg	9,150	6,350	*10,700	8,600						
4.5 m	kg	8,100	5,550	*11,650	8,300	*14,500	12,150	*19,600	19,400		
3.0 m	kg	7,600	5,150	11,550	7,900	*15,750	10,900				
1.5 m	kg	7,450	5,000	11,150	7,600	16,050	10,750				
0.0 m	kg	7,700	5,150	10,950	7,350	15,700	10,450	*15,800	*15,800		
-1.5 m	kg	8,400	5,650	10,850	7,300	15,600	10,350	*21,400	16,600		
-3.0 m	kg	9,950	6,700	10,950	7,400	*14,850	10,500	*18,750	16,900	*22,150	*22,150
-4.5 m	kg	*9,700	9,050			*11,100	10,400	*14,600	*14,600		

## PC450LC-7 – 7.06 m Boom x 2.9 m Arm x 1.9 m<sup>3</sup> Bucket SAE Heaped

A \ B		⊗ Max		7.5 m		6.0 m		4.5 m		3.0 m	
		C <sub>f</sub>	C <sub>s</sub>	C <sub>f</sub>	C <sub>s</sub>	C <sub>f</sub>	C <sub>s</sub>	C <sub>f</sub>	C <sub>s</sub>	C <sub>f</sub>	C <sub>s</sub>
6.0 m	kg	9,150	6,350	*10,700	8,600						
4.5 m	kg	8,100	5,550	*11,650	8,300	*14,500	12,150	*19,600	19,400		
3.0 m	kg	7,600	5,150	11,550	7,900	*15,750	10,900				
1.5 m	kg	7,450	5,000	11,150	7,600	16,050	10,750				
0.0 m	kg	7,700	5,150	10,950	7,350	15,700	10,450	*15,800	*15,800		
-1.5 m	kg	8,400	5,650	10,850	7,300	15,600	10,350	*21,400	16,600		
-3.0 m	kg	9,950	6,700	10,950	7,400	*14,850	10,500	*18,750	16,900	*22,150	*22,150
-4.5 m	kg	*9,700	9,050			*11,100	10,400	*14,600	*14,600		

## PC450LC-7 – 7.06 m Boom x 2.9 m Arm x 1.9 m<sup>3</sup> Bucket SAE Heaped

A \ B		⊗ Max		7.5 m		6.0 m		4.5 m		3.0 m	
		C <sub>f</sub>	C <sub>s</sub>	C <sub>f</sub>	C <sub>s</sub>	C <sub>f</sub>	C <sub>s</sub>	C <sub>f</sub>	C <sub>s</sub>	C <sub>f</sub>	C <sub>s</sub>
6.0 m	kg	8,300	5,700	*9,950	8,650						
4.5 m	kg	7,400	5,000	*10,900	8,250	*13,300	12,200	*17,700	*17,700		
3.0 m	kg	6,950	4,600	*11,400	7,850	*15,050	11,150				
1.5 m	kg	6,800	4,500	11,050	7,450	15,950	10,650				
0.0 m	kg	7,000	4,600	10,750	7,200	15,500	10,250	*21,550	16,200		
-1.5 m	kg	7,550	5,000	10,600	7,050	15,350	10,100	*22,100	16,200	*15,450	*15,450
-3.0 m	kg	8,800	5,850	10,650	7,100	*15,300	10,150	*19,800	16,450	*24,100	*24,100
-4.5 m	kg	*9,550	7,650			*12,550	10,450	16,200	16,200	*20,100	*20,100



## BACKHOE BUCKET, ARM AND BOOM COMBINATION

Contact : 9300723311

Bucket capacity (heaped)		Width		Weight with cutters / shrouds	Number of teeth	Arm length	
SAE, PCSA	CECE	W/o side cutters / shrouds	With side cutters / shrouds			2.4 m 7'10"	2.9 m 9'6"
1.9 m <sup>3</sup> 2.49 y <sup>3</sup>	1.70 m <sup>3</sup> 2.22 y <sup>3</sup>	1510 mm 59.4"	1590 mm 62.6"	2240 kg 4935 lbs	4	○	Rock
2.2 m <sup>3</sup> 2.88 y <sup>3</sup>	1.94 m <sup>3</sup> 2.54 y <sup>3</sup>	1630 mm 64.2"	1770 mm 69.7"	2120 kg 4670 lbs	5	□	Iron ore
2.6 m <sup>3</sup> 3.40 y <sup>3</sup>	2.29 m <sup>3</sup> 3.00 y <sup>3</sup>	1710 mm 67.3"	1845 mm 72.6"	2200 kg 4850 lbs	5	○	
2.85 m <sup>3</sup> 3.73 y <sup>3</sup>	2.51 m <sup>3</sup> 3.28 y <sup>3</sup>	1710 mm 67.3"	1845 mm 72.6"	2195 kg 4839 lbs	5	□	
3.1 m <sup>3</sup> 4.05 y <sup>3</sup>	2.8 m <sup>3</sup> 3.66 y <sup>3</sup>	1784 mm 70.2"	1900 mm 74.8"	2375 kg 5235 lbs	5	□	

○ : General purpose use with density upto 1.8 t/cu.m. (1.52 US ton/cu.yd.)

□ : General purpose use with density upto 1.6 t/cu.m. (1.35 US ton/cu.yd.)



## STANDARD EQUIPMENT

- Alternator, 50 Ampere, 24V
- Auto-Deceleration
- Air Cleaner (Pre-ilter)
- Air-conditioner(Cooler) Unit in Cabin
- All-weather steel cab (with multilayer viscous damping mounts, tinted safety-glass windows, pull-up type front window with lock device, removable lower windshield, lockable door, loor mat & adjustable seat)
- Automatic Engine Warm-up System
- Automatic de-aeration system for fuel line
- Batteries, 140 Ah/2 x 12V
- Boom holding valve
- Corrosion resistor
- Counterweight
- Dry type air cleaner, double element
- Electric horn
- Engine, Komatsu SAA6D125E-3
- Engine overheat prevention system
- Fan guard structure
- Fuel Lift Pump
- Fuel Filters (2 micron) – 2 Nos.
- Hydraulic track adjusters (each side)
- Monitor, 7-Seg Monitor
- Power maximizing system
- PPC hydraulic control system
- Radiator & Oil Cooler dust proof net
- Rear view mirror, R.H.
- Starter motor, 11 kW/24V x 1
- Structures reinforced
- Suction fan
- Suspension Seat
- Tool Box
- Track guiding guard, center section
- Track roller 8 each side
- Track shoe 600 mm 24" triple grouser
- Two settings for boom
- Undercarriage – LC
- Water Separator
- Working light, 2 (boom and RH)
- Working mode selection system
- One piece boom 7060 mm
- Arm 2400 mm
- Bucket 2.6 m<sup>3</sup>

### Optional Equipment

- Bolt on top guard and front guard (operator protective guard)
- Service valve

Product improvement is a continuous process. Specifications given in this publication are therefore subject to change without notice. Photographs depicted may be of optional equipment.

Shree Group Of Companies

Shree Group Of Companies

Shree Group Of Companies

Shree Group Of Companies

Shree Group Of Companies

Shree Group Of Companies

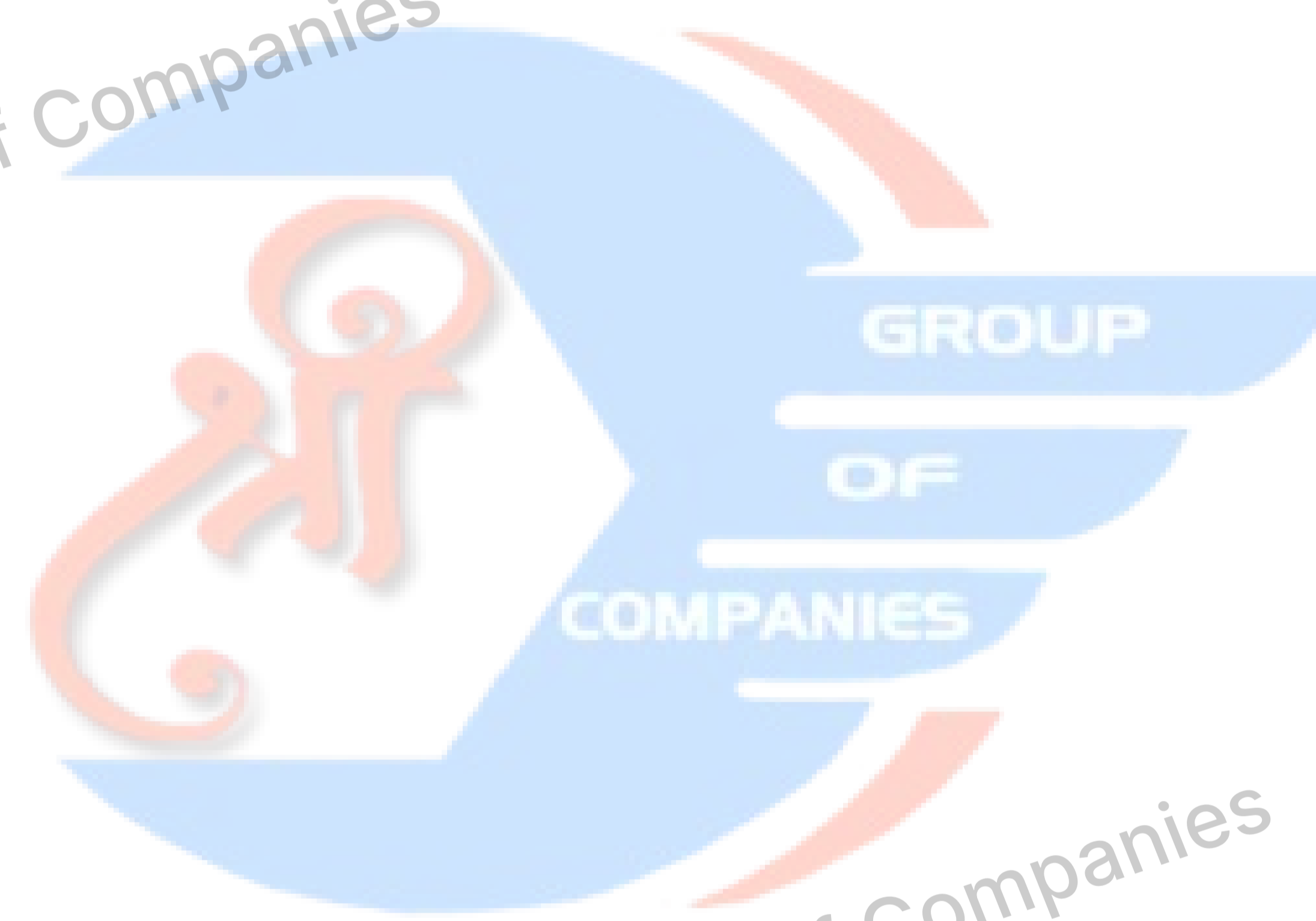

Product improvement is a continuous process. Specifications given in this publication are therefore subject to change without notice. Photographs depicted may be of optional equipment

[www.Komatsu.com](http://www.Komatsu.com)

**KOMATSU**<sup>®</sup>



Marketed & Serviced by:

**L&T Construction Equipment**

**Larsen & Toubro Limited**

1<sup>st</sup> Floor Lakshminarayan Complex, 10/1 Palace Road, Bengaluru- 560 052

Tel: 080 40401844 / 786

E-mail: [ceb@larsentoubro.com](mailto:ceb@larsentoubro.com) [www.larsentoubro.com](http://www.larsentoubro.com)

**Zonal Offices:**

**Delhi** (011) 40819500  
**Nagpur** (0712) 6606441/2260025

**Kolkata** (033) 44002433/22831442  
**Hyderabad** (040) 47575064

**Pune** (020) 48544259  
**Chennai** (044) 40706864

CIN: L99999MH1946PLC004768

Contact : 9300723311

Materials and specifications are subject to change without notice.

**KOMATSU** is a trademark of Komatsu Ltd. Japan.

### Total Versatility

Range of buckets for different applications

### Comfortable Working Environment

Low vibration with cab damper mounting  
Operator seat and console with armrest that enables operations in the appropriate posture

See page 6.



<b>HORSEPOWER</b>	Net: 330 HP 246 kW @ 1850 RPM
<b>OPERATING WEIGHT</b>	45,000 kg
<b>BUCKET CAPACITY</b>	2.6 – 3.1 m <sup>3</sup> (SAE) 2.2 m <sup>3</sup> (SAE) - Iron Ore 1.9 m <sup>3</sup> (SAE) - Granite

# PRODUCTIVITY

## Electronically - Controlled High Power Engine

The 246 kW (330 HP) Komatsu SAA6D125E-3 engine is provided in Komatsu PC450LC-7 is the largest in its class. High power and low fuel consumption are achieved by optimizing fuel injection via electronic control. It is an environment friendly engine which complies with EPA, EU and Japan Tier-2 emission regulations.



## Hydraulic System equipped with engine speed sensor

The pump is controlled by the engine speed sensor, so maximum horsepower is used at all times. This contributes to higher production and shorter cycle times.

## Two Boom Settings

**Smooth mode** provides easy operation for gathering blasted rock or scraping down operation. When maximum digging force is needed, switch to **Power mode** for more effective excavating.

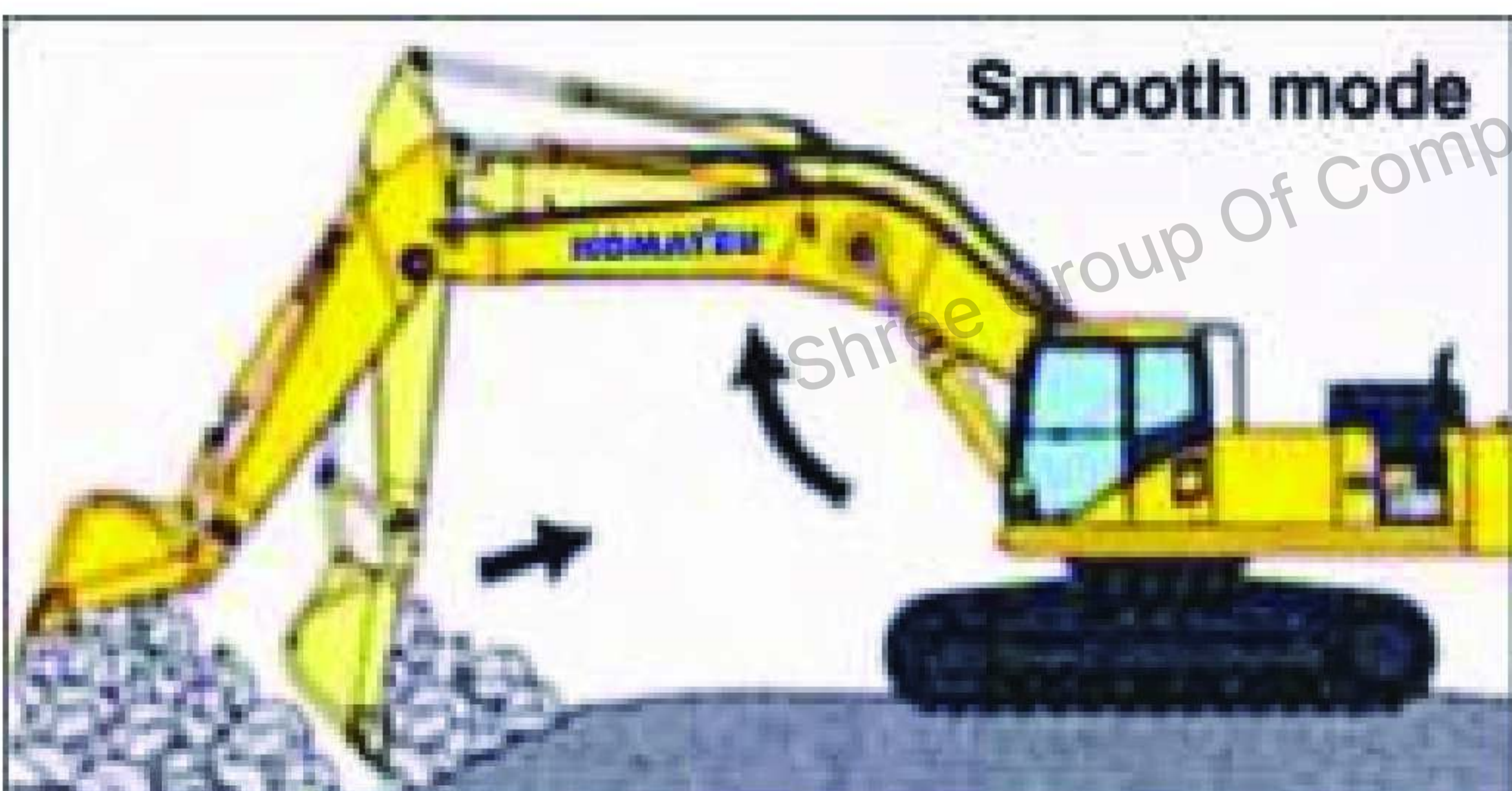

Boom floats upward, reduced lifting of machine front. This facilitates gathering blasted rock and scraping down operations.

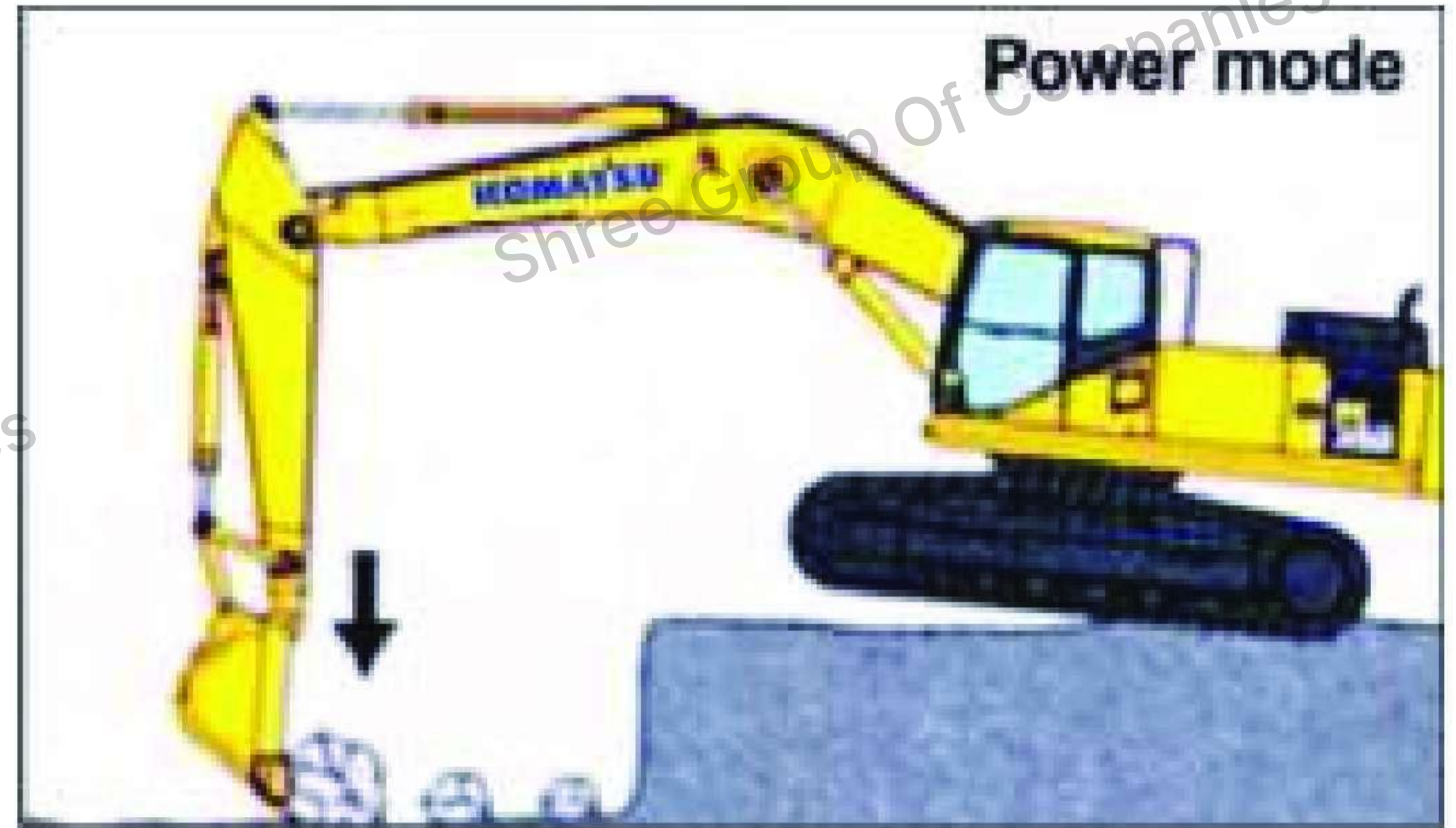

Boom pushing force is increased, ditch digging and box digging operation on hard ground are improved.

## High Production and Low Fuel Consumption

High production and low fuel consumption are achieved through the following operation modes:

### Active Mode 'A'

This mode handles large production by providing powerful and speedy operation, and achieves economic efficiency by substantial reduction in fuel consumption.

### Economy Mode 'E'

Operation speed equal to that of the Active mode can be achieved when handling light duty operation while also keeping low fuel consumption.

### Breaker Mode 'B'

Hydraulic flow is maintained at optimum engine RPM to match special attachment requirements.

# ADVANCED HYDRAULICS

## What is HydraMind?

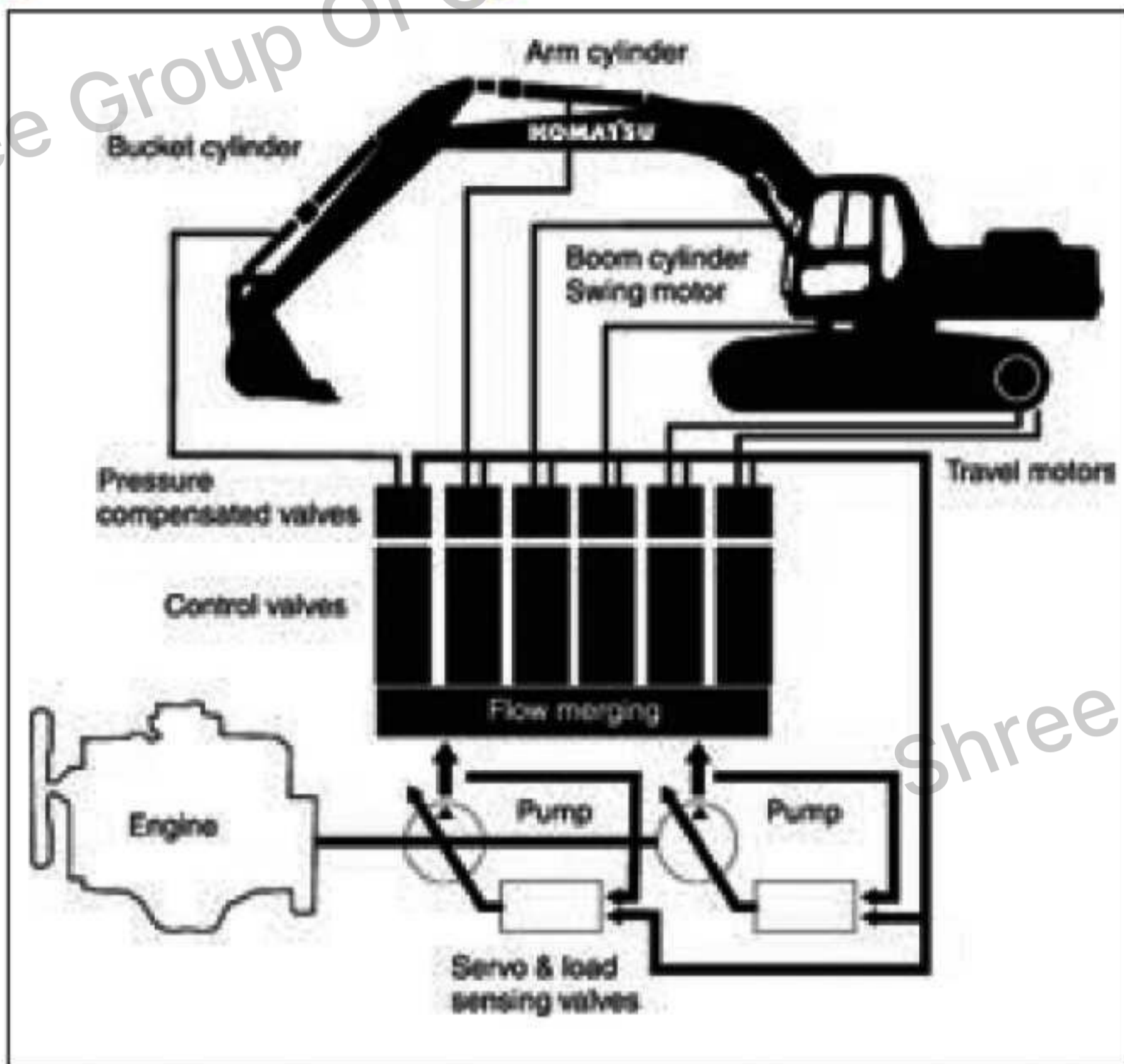

It's a technologically complex yet mechanically simple system which supervises the work operations of the excavator. Its strength lies in its simplicity.

The system incorporates many major breakthroughs and has earned Komatsu almost 200 patents.

## What are the benefits of the HydraMind?

Power, versatility, manoeuvrability, control stability – you name it. Never has an excavator been so easy to operate, so natural, so intuitive. In a sense, you don't really operate it at all, you wear it.

*For example, when the ground condition changes in digging...*

You don't have to think about changing your lever strokes because the HydraMind instantly, silently, automatically sends just the right amount of oil to the actuators at just the right pressure to accommodate the change.

When you move the boom, arm and bucket at the same time...

All the equipment works organically with the optimum combination of speed and power as if it were a human hand.

The HydraMind also makes it easy to change or add valves and work equipment. Moreover, because the system is hydraulic and not electronic, it ensures the best service availability in the industry.

## The HydraMind System Makes Everything Easier

**It is easier to fully load the buckets.**

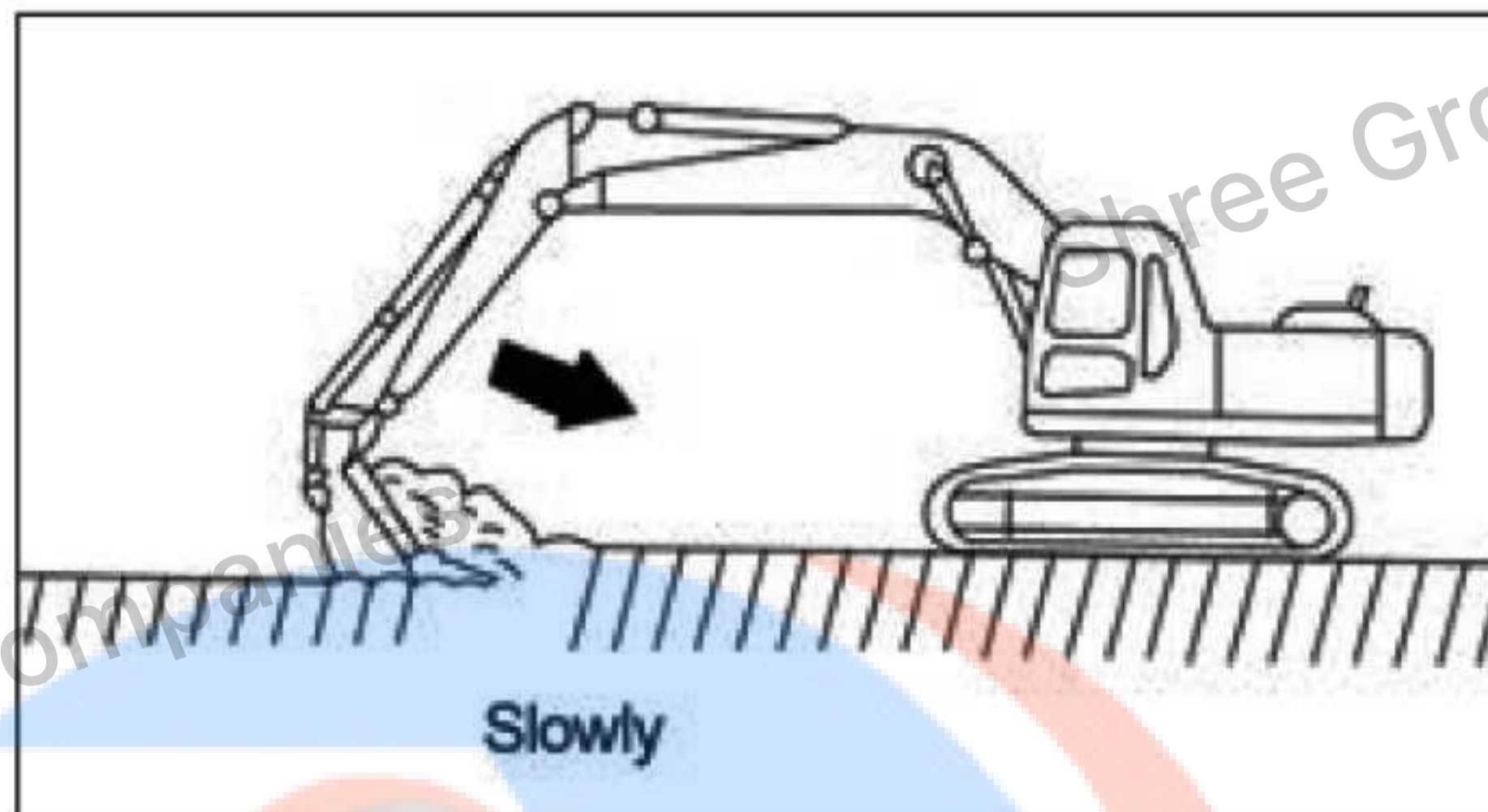

During simultaneous operations, the work equipment moves slowly at maximum power, without being influenced by the other actuators, so it is easy to fully load the bucket.

**It is easy to carry out digging work along the face of walls**

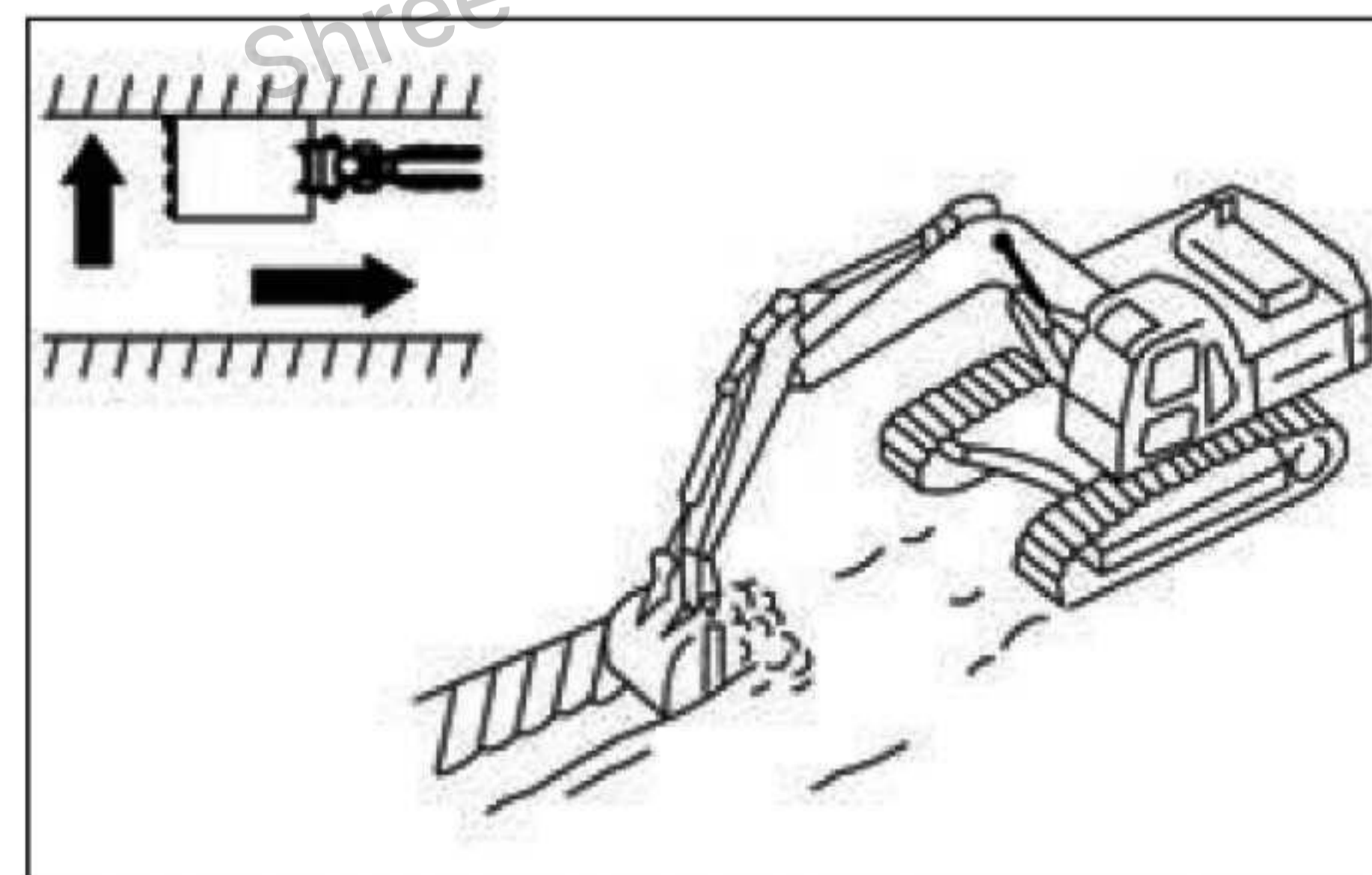

Lateral power pushing is powerful, allowing digging operation to be carried out efficiently.

**The machine can carry out operations easily without any undue chassis vibration**

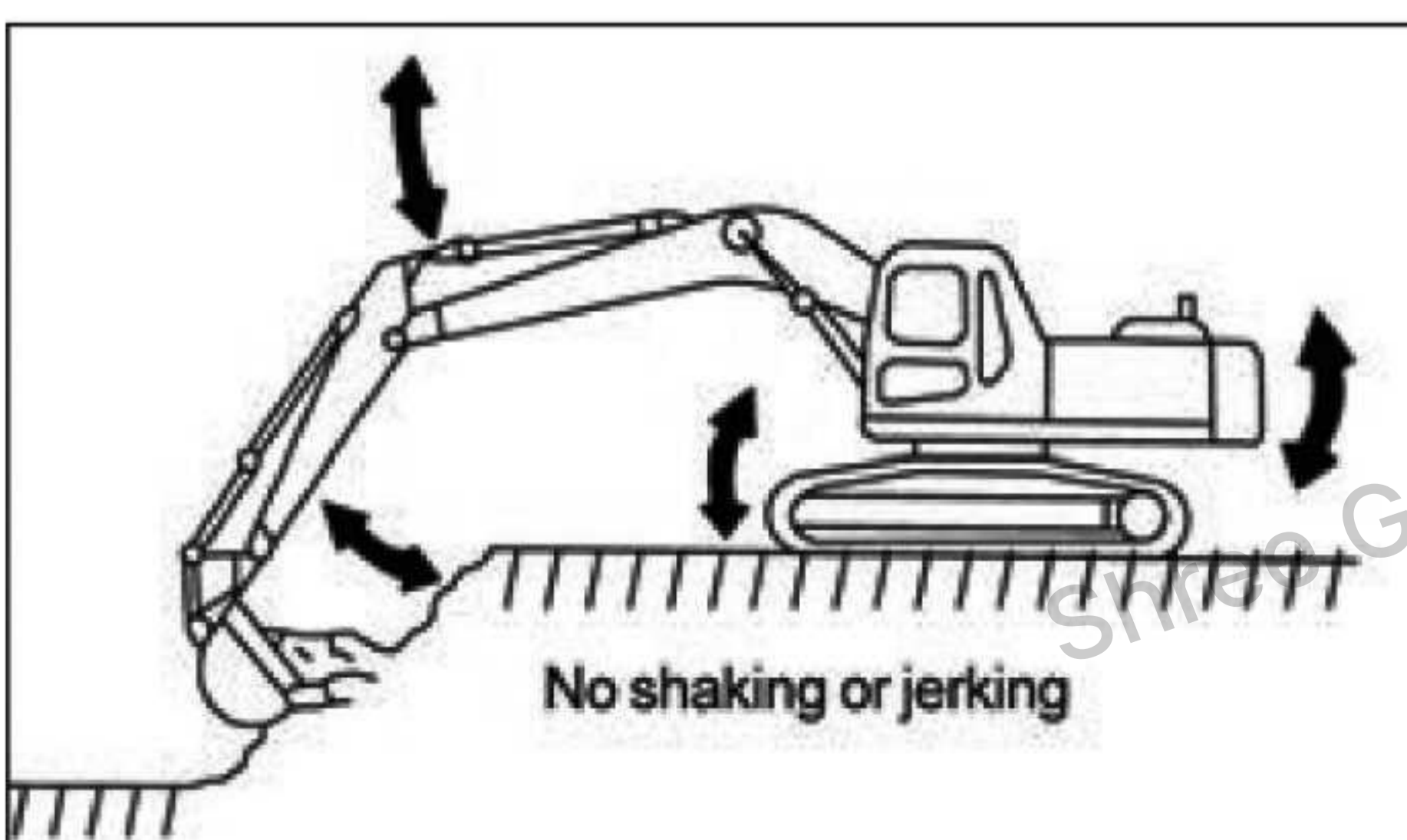

During simultaneous operations, there is no change in the work equipment speed caused by change in load. Thus, there is minimal chassis vibration.

**It is easy to scrape down**

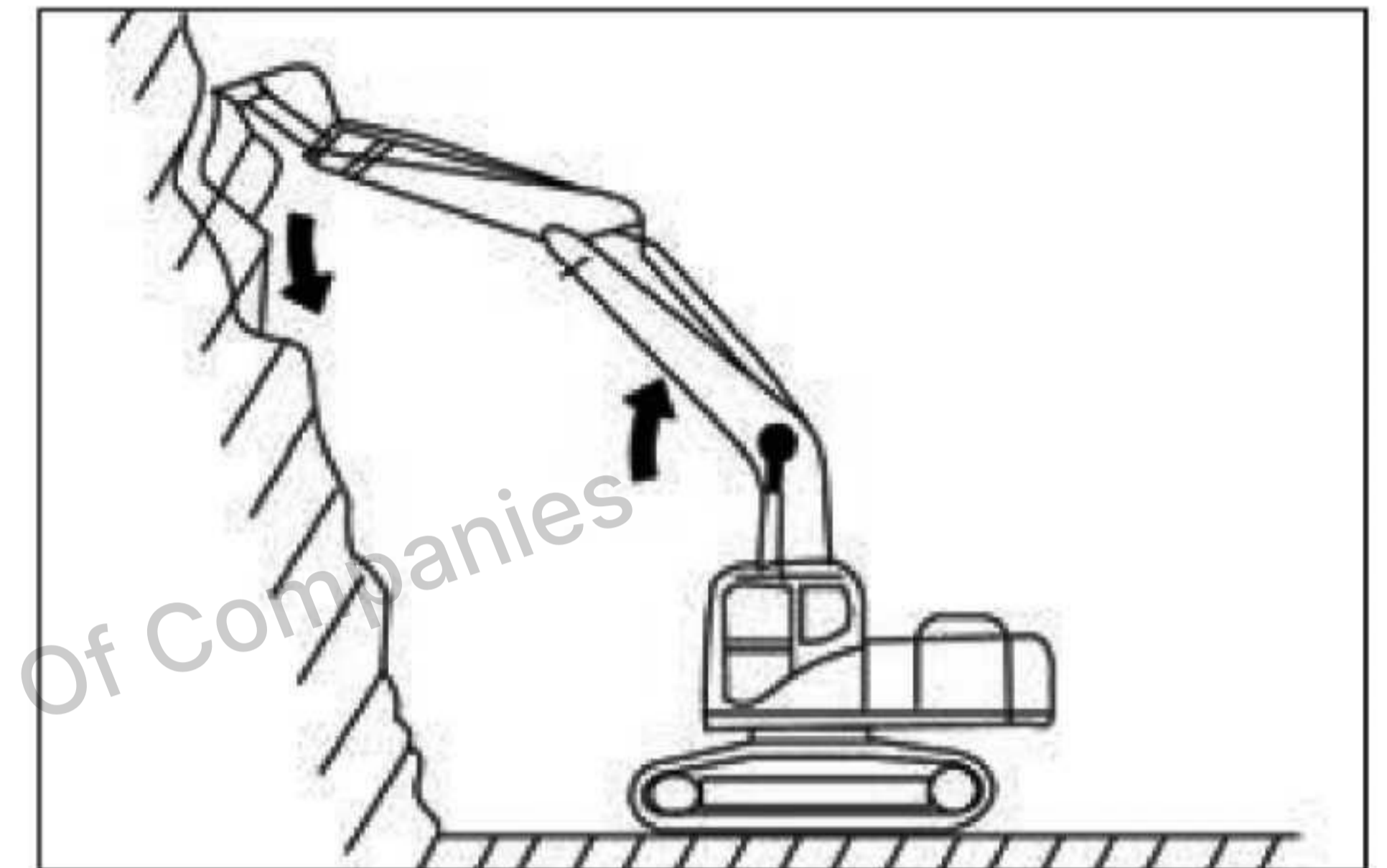

Even without operating the lever to the maximum position, maximum digging power can be obtained, making it possible to carry out slow control.

**It is easy to dig soft rock or dig up boulders**

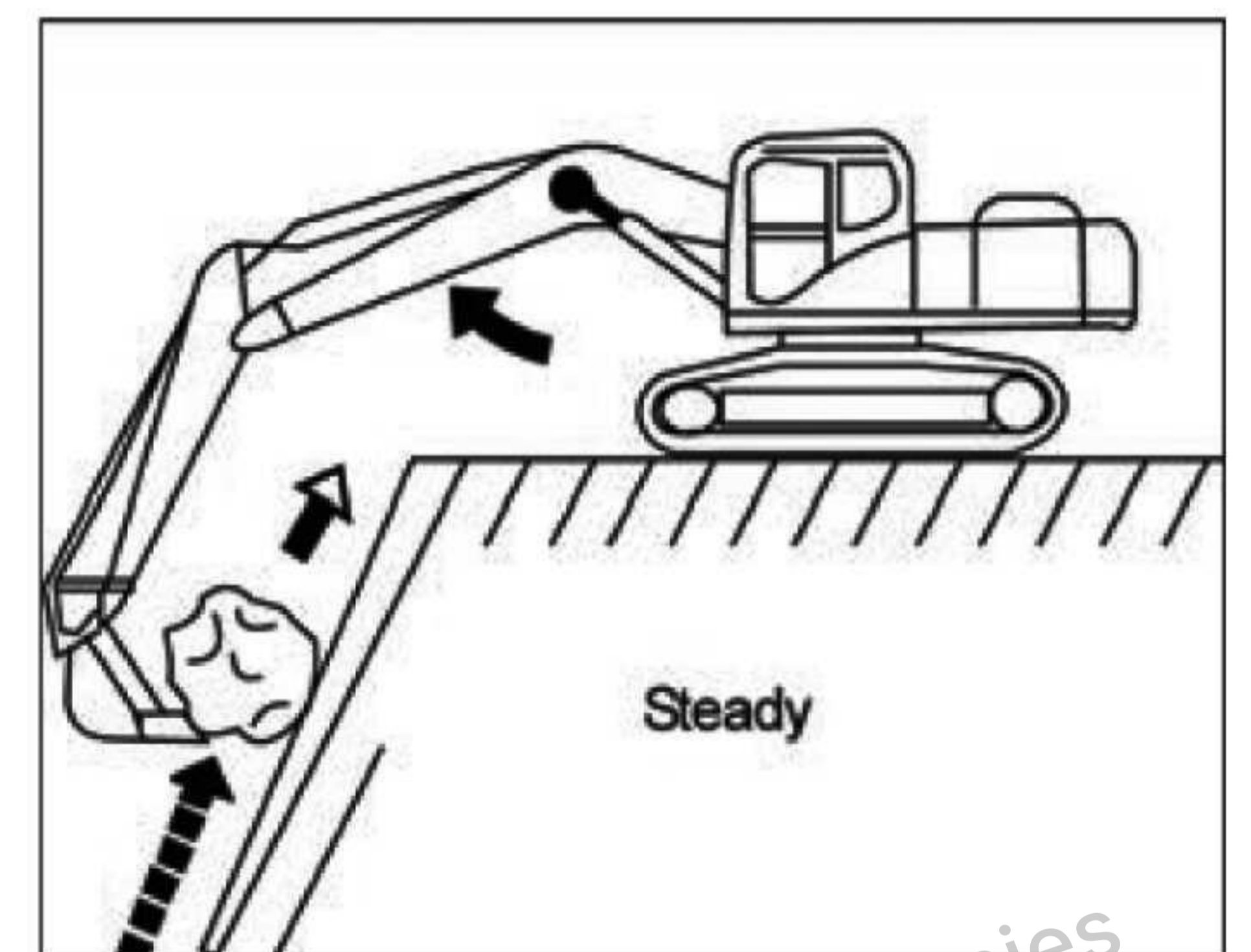

It is easy to control the boom RAISE, so the cutting edge does not deviate from the boulders

# COMFORT

## Spacious cabin

The cabin is spacious and air-cooled. An ergonomically-designed operator's seat and easy access to all control levers ensure maximum operator comfort and better concentration on the job.



## Comparison of Riding Comfort Cab Damper Mounting



## Multi-Layer Viscous Mount

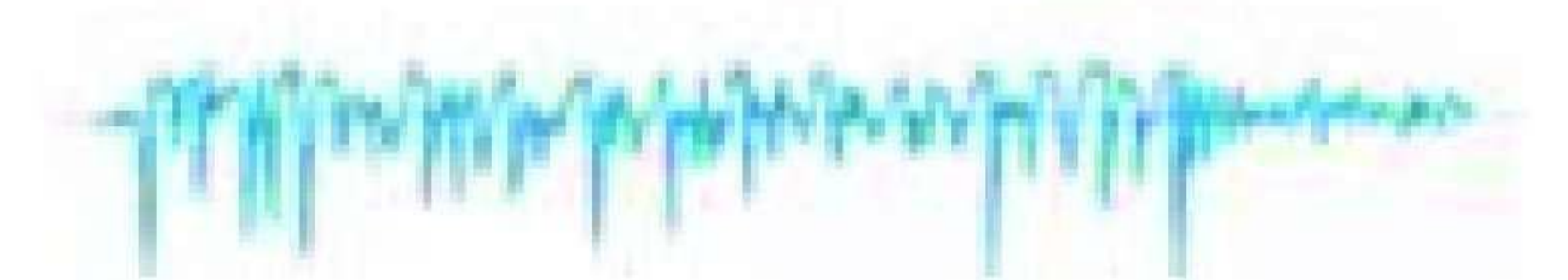

Conditions: – Floor vibration while travelling forward at high speed over obstacles. Pitch vertical direction on graph shows size of vibration

## Adjustable seat and control levers

The suspension seat slides forward and backward together with the work equipment control levers to ensure the best operating position at all times.



## Low Vibration with Cab Damper Mounting

Komatsu PC450LC-7 uses a new, improved cab damper mount system that incorporates longer stroke and the addition of a spring. The new cab damper mounting combined with a strengthened left and right side deck aids vibration reduction at the operator's seat.

## Lock Lever

Locks the hydraulic pressure to prevent unintentional movement. Neutral start function only allows machine to be started in lock position.

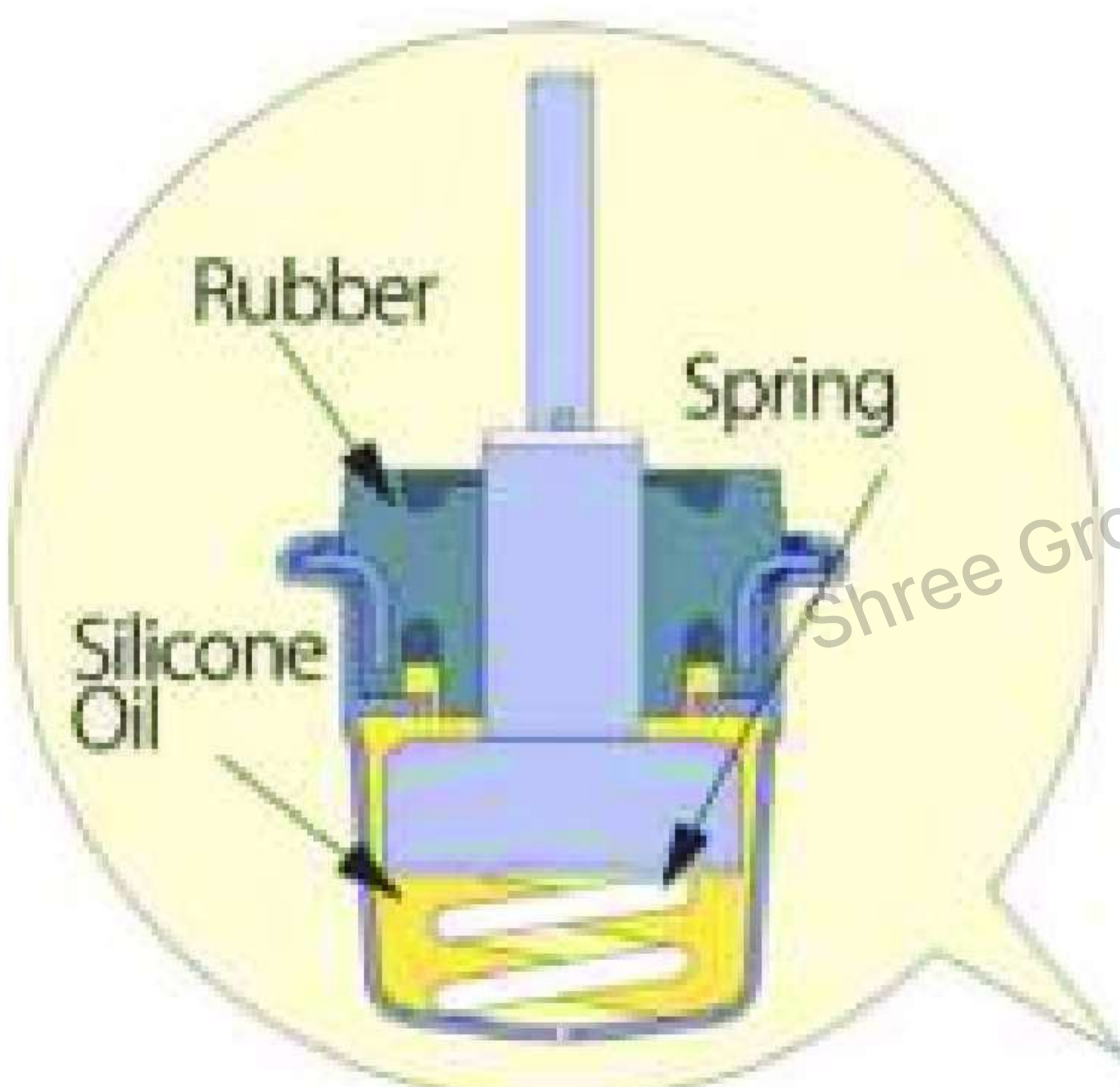

# PRODUCTIVITY

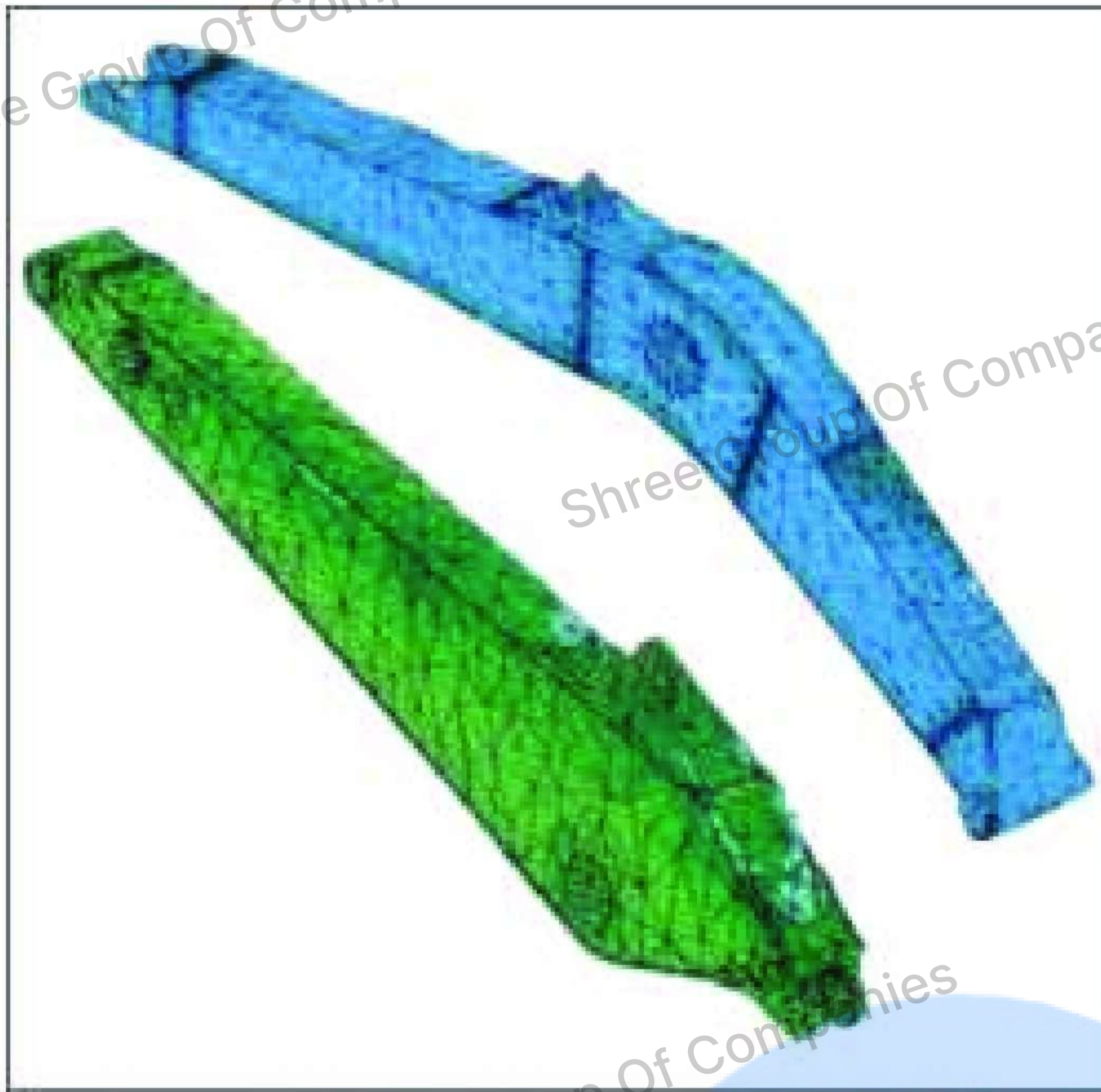

## Highly Reliable Electronic Devices

Exclusively designed electronic devices have passed severe testing.

- Controller
- Sensors
- Connectors

Heat-resistant wiring Metal Guard Rings protect all the hydraulic cylinders and improve reliability.

## Track Link with Strut

Komatsu PC450LC-7 uses track links with strut providing superb durability.



## Sturdy Frame Structure

The revolving frame, center frame, under carriage and attachment structure are designed by using advanced three-dimensional CAD and FEM analysis technology.



## Grease Sealed Track

PC450LC-7 uses grease sealed tracks for extended undercarriage life.

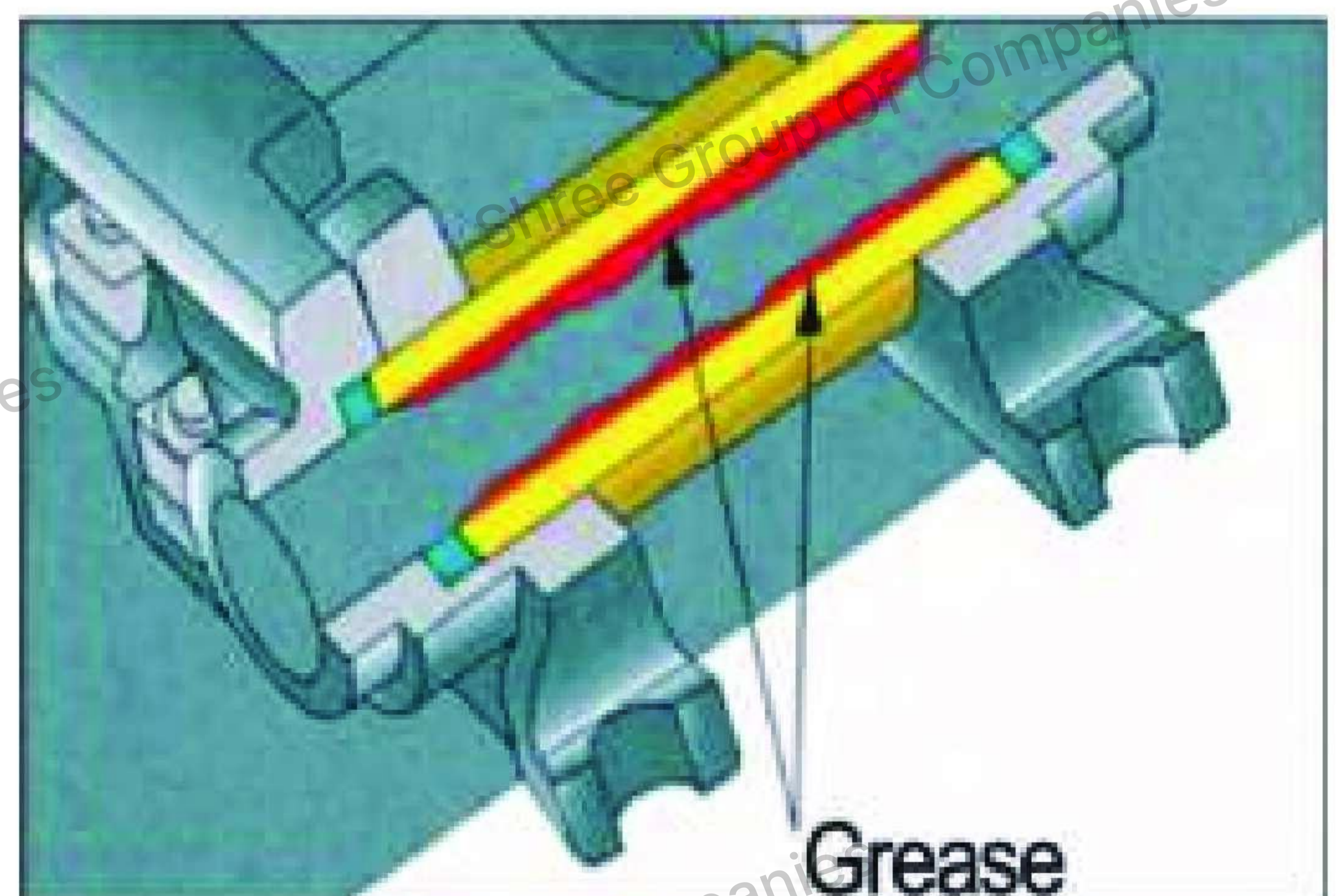

## Reliable Components

All the major machine components, such as engine, hydraulic pumps, hydraulic motors and control valves are exclusively designed and manufactured by Komatsu.

# MAINTENANCE

## Self-Diagnostic Monitor

Komatsu PC450LC-7 features an advanced diagnostics system. The Komatsu exclusive system identifies maintenance items, reduces diagnostic times, indicates oil and filter replacement hours and displays error codes.

## Continuous Machine Monitoring System

When turning starting switch ON, check-before-starting item and caution items appear on the liquid crystal panel. If abnormalities are found, a warning lamp blinks and a warning buzzer sounds. The continuous machine condition checks help prevent the development of serious problems and allows the operator to concentrate on the controls.

## Abnormalities on Electronic System Display with Code

When an error occurs during operation, a user code is displayed. When an important user code is displayed, a caution lamp blinks and a warning buzzer sounds to prevent the development of serious problems.

## Oil Maintenance Function

When machine exceeds oil or filter replacement time, oil maintenance monitor lights up to inform operator.



**A.** Engine Water Temperature

**B.** Battery Charge

**C.** Engine Oil Pressure

**D.** Air Cleaner Clogging Monitor

**E.** Auto-Decel Switch

**F.** Travel Speed Select Switch

**G.** Working Mode Select Switch

**H.** Fuel Lever Monitor

**I.** User or Trouble Code Display

**J.** Service Meter Display

**K.** Engine Oil Level

**L.** Engine Preheat

**M.** Swing Lock Display

**N.** Oil Maintenance

# SAFETY

## Pump/Engine Room Partition

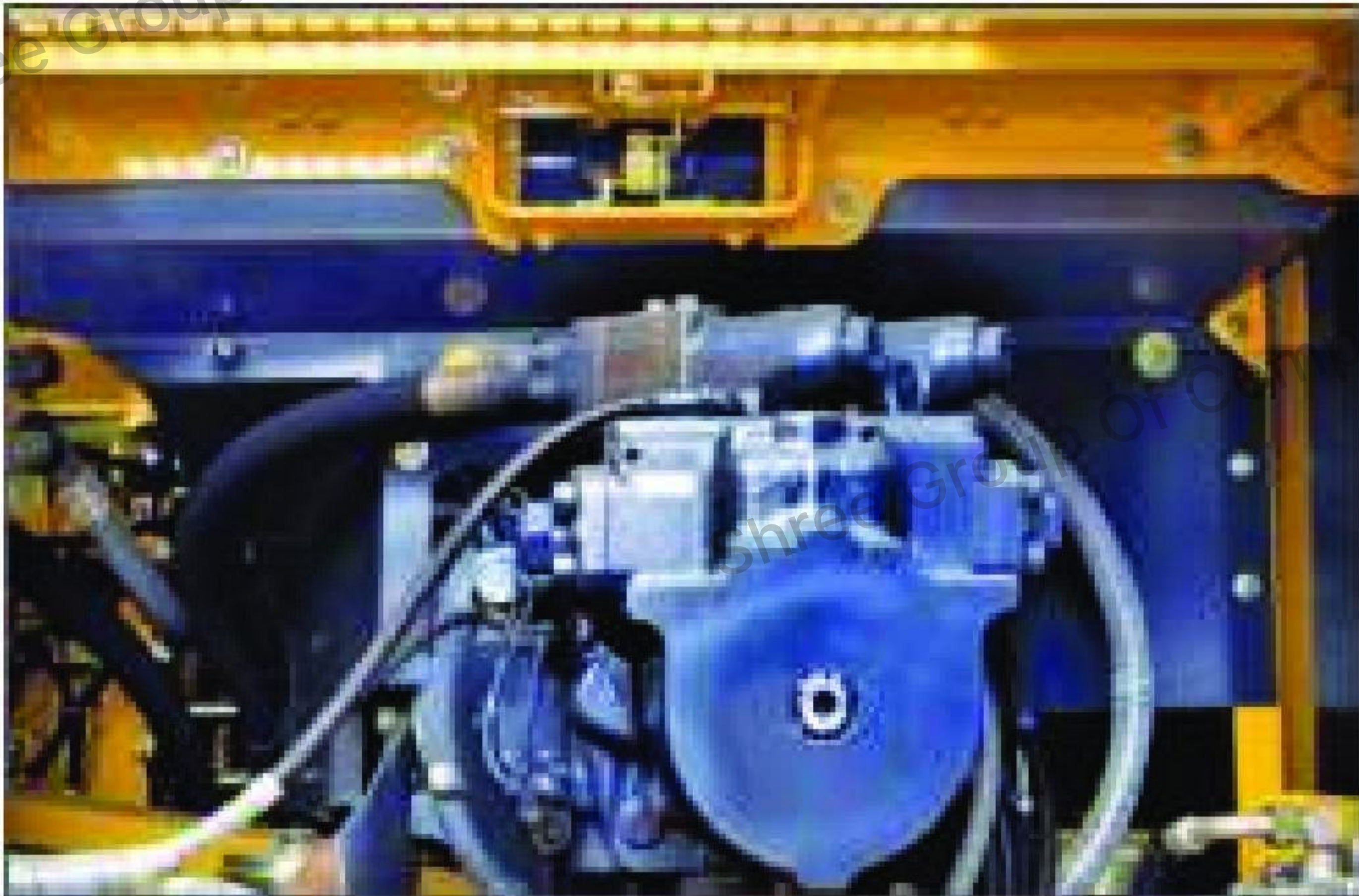

Prevents oil from spraying on the engine if a hydraulic hose bursts.



## Protective Guards

Thermal guard placed around high temperature parts of the engine provides adequate protection against accidental contacts, while the fan guard wards off impending hazards.



## Non-skid sheet and large handrail

Steps with non-skid sheet provide safe grip when on the machine for maintenance work, while the large handrail with a provision to mount rear view mirror, supports easy climbing.



## Easy Maintenance Radiator & Oil Cooler

Removal and installation of the radiator and oil cooler are made easier by locating side-by-side.



## Reduced Maintenance Costs

Uses high performance filtering materials and long life oil. Extends the oil & filter replacement interval.

## High-capacity Air Cleaner

High-capacity air cleaner is comparable to that of larger machine. The pre-cleaner can extend air cleaner life during long-term operation and prevents early clogging resulting in power decrease. Reliability is improved by a new seal design. Additional pre-air cleaner is provided to enhance the life of air filter.

## Large Size Fuel Tank

Fuel tank capacity is 650 ltr (172 U.S gal) for extending operating hours before refueling. The fuel tank is treated for rust prevention and improved corrosion resistance.

## Easy Access for Engine Inspection

Engine oil check pipe and oil filter are located on the left side of the engine to facilitate easy access for engine inspection.



# KOMATSU TOTAL SUPPORT



## Komatsu Total Support

To keep your machine available and minimize operation cost when you need it, Komatsu Distributor is ready to provide variety of support before and after procuring the machine.

### Fleet recommendation

Komatsu Distributor can study customer job site and provide the most optimum fleet recommendation with detailed information to meet all of your application needs when you are considering to buy new machines or to replace the existing ones from Komatsu.



### Product support

Komatsu Distributor secure the certain quality of machine will be delivered.

### Parts availability

Komatsu Distributor is available for emergency inquiry by the customers for genuine, quality guaranteed Komatsu parts.

### Technical support

Komatsu product support service (Technical support) are designed to help customer. Komatsu Distributor offers a variety of effective services how much Komatsu is dedicated to the maintenance and support of Komatsu machine.

- Preventive Maintenance (PM) clinic
- Oil & Wear analysis program

### Repair & maintenance service

Komatsu Distributor offers quality repair service, periodical maintenance, and maintenance service to the customer, utilizing and promoting Komatsu developed programs.

### Komatsu Reman (Remanufactured) components

Komatsu Reman products are the result of the implementation of the Komatsu global Reman policy which establishes and agrees to reduce the owning, operating and total Life Cycle Costs (LCC) to Komatsu's customer through prompt delivery, high quality and competitively priced in own remanufactured products (QDC).

